



# PLANETARY GEARBOX CATALOG

WANSIN  
WANSIN<sup>®</sup>

WANSIN SEIKOU (HUNAN) CO., LTD

Website: [www.wansin.com](http://www.wansin.com)

Add. : WANSIN Industrial Park, Ningxiang Hi-tech Zone, Changsha City, Hunan Province, China 410600

Tel. : +86 731 82247038

Email : [sales@wansin.com](mailto:sales@wansin.com)



Committed To Building Enduring Highly-precision Gearbox

SPECIALIZED REDUCER / REDUCTION MOTOR / INVERTER MANUFACTURER

INTELLIGENT AUTOMATION SOLUTION PROVIDER



## CONTENTS

03-09	<b>WAD</b> <small>Series Planetary Gearbox</small>
10-15	<b>WVRB</b> <small>Series Planetary Gearbox</small>
16-21	<b>WAE</b> <small>Series Planetary Gearbox</small>
22-26	<b>WADR</b> <small>Series Planetary Gearbox</small>
27-31	<b>WVRBR</b> <small>Series Planetary Gearbox</small>
32-36	<b>WAER</b> <small>Series Planetary Gearbox</small>
37-53	<b>WAT</b> <small>Series Planetary Gearbox</small>
54-72	<b>WTN</b> <small>Series Hollow Rotating Platform</small>
73-74	Selection of Planetary Gearbox
75-77	Installation & Usage

## WANSHSIN Seikou(Hunan)Co., Ltd.



WANSHSIN is a professional gearbox, gear motor and inverter manufacturer and intelligent automation complete solution provider, integrating R&D, production, sales and service. The products cover the light and heavy industry, are widely used in new energy, robots, automobile manufacturing, warehousing, logistics, food industry and other industries. WANSHSIN has gradually become a reliable long-term partner of those leading enterprises of relevant industries.

### Enterprise Honor

2019	2020	2022
<ul style="list-style-type: none"> <li>National high-tech enterprise</li> </ul>	<ul style="list-style-type: none"> <li>Ministry of Industry and Information Technology of the People's Republic of China "specialized, special and new" key small giant enterprise</li> <li>Hunan Enterprise Technology Center</li> </ul>	<ul style="list-style-type: none"> <li>2022 Hunan Reducer Engineering Technology Research Center</li> <li>2022 The 2nd Ningxiang Mayor Quality Award(Organization)</li> </ul>

## Core Competitiveness



### Leading R&D Capability

Three major R&D centers have been established to lead the industry's high-quality development with innovation.

### Excellent Quality

We are the pioneer in introducing and launching the advanced automotive industry quality control standards pre-planning of product quality and have equipped with a large number of imported international advanced inspection/testing equipment to ensure product quality.

### Advanced Manufacturing

We have hundreds of domestic advanced processing equipment with a total value of more than 100 million yuan, and our capacity is in a leading position in China.

### Fast Delivery

Sufficient spare parts in warehouse to ensure very short lead time.

## WAD



Series Planetary Gearbox

## WVRB



Series Planetary Gearbox

## WAE



Series Planetary Gearbox

## WADR



Series Planetary Gearbox

## WVRBR



Series Planetary Gearbox

## WAER



Series Planetary Gearbox

## WAT



Series Planetary Gearbox

## WTN



Series Hollow Rotating Platform

# WAD

 Series  
Planetary Gearbox

## FEATURES

- » The planet gear carrier and output end adopt an integrated double-supported structure design to ensure maximum torsional rigidity, toughness, and rotational accuracy.
- » The planet gear adopts a full needle roller design to increase the contact area and improve the structural rigidity and output torque.
- » The gear uses low carbon steel carburized and quenched to achieve a surface hardness of HRC62 to obtain the best wear resistance and impact toughness.
- » The gear profile is designed with assistance from imported software to obtain the best possible design, thereby reducing noise.
- » The connection between the input end and the motor shaft adopts a double-sided clamping method to achieve maximum clamping force and zero backlash power transmission.





## SELECTION

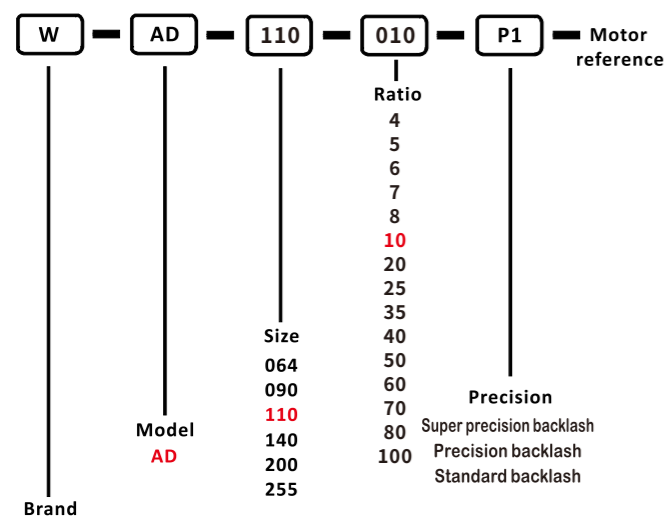

## GENERAL NOTICES

- Type, model and torque
- Ratio or output speed
- Working conditions and connection methods
- Quantity and installed machine name
- Input mode and input speed
- Motor brand model or flange and motor shaft size

## PLANETARY GEARBOX

### Performance

Specification	Unit	Stage	Ratio	WAD064	WAD090	WAD110	WAD140	WAD200	WAD255		
Rated output torque $T_{2N}$	Nm	1	4	48	130	270	560	1100	1700		
			5	60	160	330	650	1200	2000		
			6	50	140	300	550	1100	1800		
			7	50	140	300	550	1100	1800		
			8	40	100	230	450	900	1500		
		10	40	100	230	450	900	1500			
		2	20	48	130	270	560	1100	1700		
			25	60	160	330	650	1200	2000		
			35	50	140	300	550	1100	1800		
			40	48	130	270	560	1100	1700		
50	60		160	330	650	1200	2000				
Emergency stop torque $T_{2NOT}$	Nm	1,2	4 ~ 100	Triple rated output torque							
			Rated input speed $n_{1N}$	rpm	4 ~ 100	5000	4000	4000	3000	3000	2000
			Maximum input speed $n_{1B}$		4 ~ 100	10000	8000	8000	6000	6000	4000
Super precision backlash $P_0$	arcmin	1	4 ~ 10	≤1.5	≤1.5	≤1.5	≤1.5	≤1.5	≤1.5		
		2	20 ~ 100	≤3	≤3	≤3	≤3	≤3	≤3		
Precision backlash $P_1$	arcmin	1	4 ~ 10	≤3	≤3	≤3	≤3	≤3	≤3		
		2	20 ~ 100	≤5	≤5	≤5	≤5	≤5	≤5		
Standard backlash $P_2$	arcmin	1	4 ~ 10	≤5	≤5	≤5	≤5	≤5	≤5		
		2	20 ~ 100	≤8	≤8	≤8	≤8	≤8	≤8		
Torsional rigidity	Nm/arcmin	1,2	4 ~ 100	13	31	82	151	440	1006		
Maximum bending torque $M_{2KB}$	Nm	1,2	4 ~ 100	125	235	430	1300	3064	5900		
Allowable axial force $F_{2aB}$	N	1,2	4 ~ 100	1050	2850	2990	10590	16660	29430		
Lifespan	hr	1,2	4 ~ 100	20000							
Efficiency	%	1	4 ~ 10	≥97%							
		2	20 ~ 100	≥94%							
Weight	kg	1	4 ~ 10	1.1	2.9	5.4	11.9	31.6	56.1		
		2	20 ~ 100	1.7	4.2	8	15.9	36.9	70.4		
Use of temperature	°C	1,2	4 ~ 100	-20°C~+40°C							
Lubricating		1,2	Synthetic lubricating grease								
IP Grade		1,2	4 ~ 100	IP65							
Installation direction		1,2	4 ~ 100	In any direction							
Noise level ( $n_1=3000\text{rpm}$ , off load)	dB(A)	1,2	4 ~ 100	≤58	≤60	≤63	≤65	≤67	≤70		

# ROTATIONAL INERTIA OF REDUCER

## Rotational inertia

Specification	Unit	Stage	Ratio	WAD064	WAD090	WAD110	WAD140	WAD200	WAD255
Rotational inertia J1	kg · cm <sup>2</sup>	1	4	0.14	0.51	2.87	7.54	25.03	58.31
			5	0.13	0.47	2.71	7.42	23.29	53.27
			6	0.13	0.45	2.61	7.14	22.48	50.97
			7	0.13	0.45	2.67	7.14	22.48	50.97
			8	0.13	0.44	2.57	7.03	22.51	50.56
			10	0.13	0.44	2.57	7.03	22.51	50.56
		2	20	0.03	0.13	0.47	2.71	7.42	23.29
			25	0.03	0.13	0.47	2.71	7.42	23.29
			35	0.03	0.13	0.47	2.71	7.42	23.29
			40	0.03	0.13	0.44	2.57	7.03	22.51
			50	0.03	0.13	0.44	2.57	7.03	22.51
			60	0.03	0.13	0.44	2.57	7.03	22.51
		70	0.03	0.13	0.44	2.57	7.03	22.51	
		80	0.03	0.13	0.44	2.57	7.03	22.51	
		100	0.03	0.13	0.44	2.57	7.03	22.51	

1. Ratio (  $i=N_{in}/N_{out}$  )

2. Maximum acceleration torque  $T_{2B} = 60\%$  of  $T_{2NOT}$

3. Output speed 100rpm, acting on the center of the output shaft

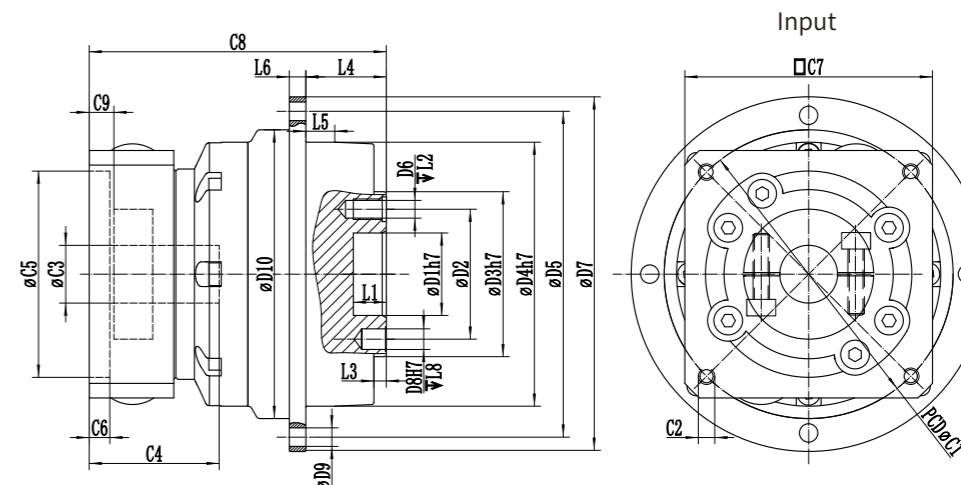

## DIMENSION SINGLE SECTION

Dimension(single stage, Ratio i=4~10)

Dimension	WAD064	WAD090	WAD110	WAD140	WAD200	WAD255
D1 H7	20	31.5	40	50	80	100
D2	31.5	50	63	80	125	140
D3 h7	40	63	80	100	160	180
D4 h7	64	90	110	140	200	255
D5	79	109	135	168	233	280
D6	7×M5×0.8P	7×M6×1P	11×M6×1P	11×M8×1.25P	11×M10×1.5P	12×M16×2.0P
D7	86	118	145	179	247	300
D8 H7	5	6	6	8	10	12
D9	8×4.5	8×5.5	8×5.5	12×6.6	12×9	16×13.5
D10	70	95	125	152	212	255
L1	8	12	12	12	16	20
L2	8	13.5	13.5	17	22.5	30.5
L3	3	6	6	6	8	12
L4	19.5	30	29	38	50	66
L5	7	10	10	14.6	15	20
L6	4	7	8	10	12	18
L7	7.7	7.5	10	12	15	20
L8	6	7	7	7	10	10
C1	70 90	90 145	145 200	200	200	235
C2	M4 M5	M5 M8	M8 M12	M12*1.75P	M12*1.75P	M12*1.75P
C3	≤14 ≤19	≤19 ≤24	≤24 ≤35	≤35/≤42	≤42	≤42/≤55
C4	31.5 41	41 59	60 81	81	114	117
C5	50 70	70 110	110 114.3	114.3	114.3	200
C6	5 5	6 14	14 19	19	24	20
C7	60 80	80 130	130 180	180	180	220
C8	76 89	102 120	127.5 149.5	173.5	225.5	268.5
C9	6 9	9.5 21.5	19.5 25	22	30	36

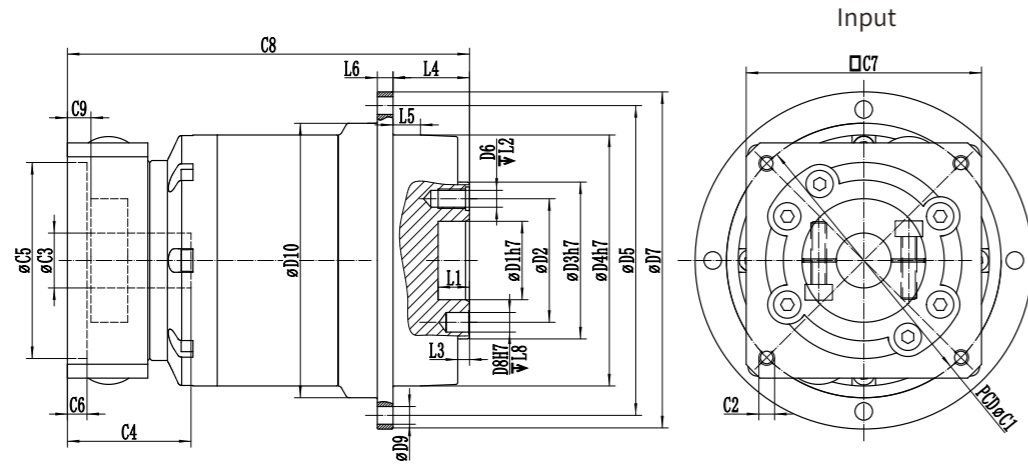

## DIMENSION DOUBLE SECTION

Dimension(double stage,Ratio i=20~100)

Dimension	WAD064		WAD090		WAD110		WAD140		WAD200		WAD255	
D1 H7	20		31.5		40		50		80		100	
D2	31.5		50		63		80		125		140	
D3 h7	40		63		80		100		160		180	
D4 h7	64		90		110		140		200		255	
D5	79		109		135		168		233		280	
D6	7×M5×0.8P		7×M6×1P		11×M6×1P		11×M8×1.25P		11×M10×1.5P		12×M16×2.0P	
D7	86		118		145		179		247		300	
D8 H7	5		6		6		8		10		12	
D9	8×4.5		8×5.5		8×5.5		12×6.6		12×9		16×13.5	
D10	70		95		125		152		212		255	
L1	8		12		12		12		16		20	
L2	8		13.5		13.5		17		22.5		20	
L3	3		6		6		6		8		12	
L4	19.5		30		29		38		50		66	
L5	7		10		10		14.6		15		20	
L6	4		7		8		10		12		18	
L7	7.7		7.5		10		12		15		20	
L8	6		7		7		7		10		10	
C1	70	90	70	90	145	90	145	145	200	200	200	200
C2	M4	M5	M4	M5	M8	M5	M8	M8*1.25P	M12*1.75P	M12*1.75P	M12*1.75P	M12*1.75P
C3	≤14	≤19	≤14	≤19	≤24	≤19	≤24	≤24/≤28	≤35	≤35	≤35	≤42
C4	31.5	41	31.5	41	59	41	60	66	80	80	80	114
C5	50	70	50	70	110	70	110	110	114.3	114.3	114.3	114.3
C6	5	5	5	6	14	6	14	19	9	9	9	30
C7	60	80	60	80	130	80	130	180	180	180	180	180
C8	108	121	123	139.5	157.5	142	172.5	234.5	260	260	260	364
C9	6	9	9.5	21.5	19.5	25	25	22	30	30	30	36

## DIMENSION

### OUTPUT SHAFT DISK SURFACE

Output Shaft Disk Dimension

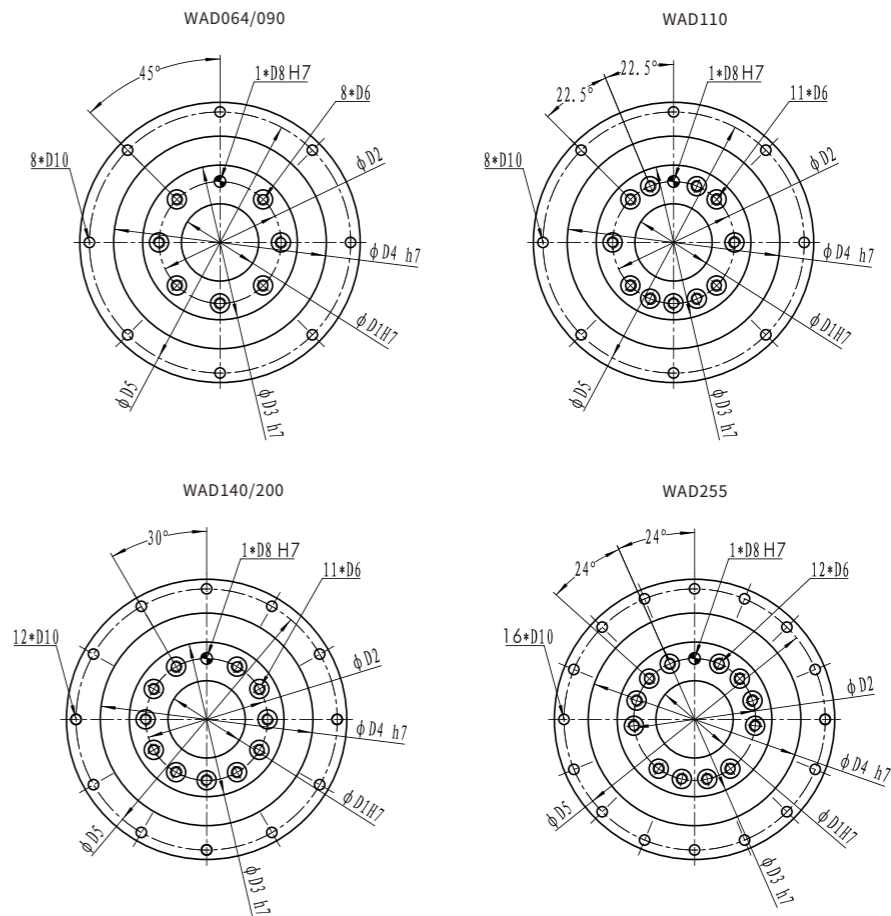

Dimension	WAD064	WAD090	WAD110	WAD140	WAD200	WAD255
D1 H7	20	31.5	40	50	80	100
D2	31.5	50	63	80	125	140
D3 h7	40	63	80	100	160	180
D4 h7	64	90	110	140	200	255
D5	79	109	135	168	233	280
D6	M5*0.8P	M6*1.0P	M6*1.0P	M8*1.25P	M10*1.5P	M16*2.0P
D8 H7	5	6	6	8	10	12
D10	4.5	5.5	5.5	6.8	9	13.5

# WVRB Series Planetary Gearbox

## FEATURES

- » The planet gear carrier and output end adopt an integrated double-supported structure design to ensure maximum torsional rigidity, toughness, and rotational accuracy.
- » The planet gear adopts a full needle roller design to increase the contact area and improve the structural rigidity and output torque.
- » The gear uses low carbon steel carburized and quenched to achieve a surface hardness of HRC62 to obtain the best wear resistance and impact toughness.
- » The gear profile is designed with assistance from imported software to obtain the best possible design, thereby reducing noise.
- » The connection between the input end and the motor shaft adopts a double-sided clamping method to achieve maximum clamping force and zero backlash power transmission.



## SELECTION

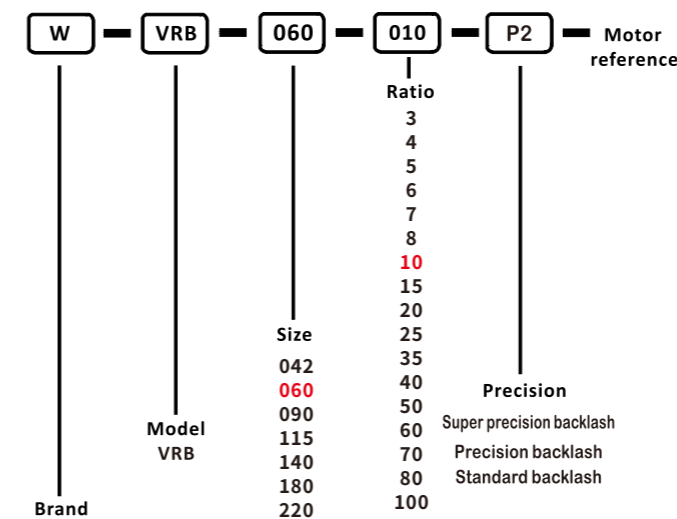

## GENERAL NOTICES

- Type, model and torque
- Ratio or output speed
- Working conditions and connection methods
- Quantity and installed machine name
- Input mode and input speed
- Motor brand model or flange and motor shaft size



# PLANETARY GEARBOX

## Performance

Specification	Unit	Stage	Ratio	WVRB042	WVRB060	WVRB090	WVRB115	WVRB140	WVRB180	WVRB220
Rated output torque $T_{2N}$	Nm	1	3	19	50	130	208	342	588	1140
			4	20	55	140	290	542	1050	1700
			5	22	60	160	330	650	1200	2000
			6	20	55	150	310	600	1100	1900
			7	19	50	140	300	550	1100	1800
			8	17	45	120	260	500	1000	1600
			10	14	40	100	230	450	900	1500
		2	15	19	50	130	208	342	588	1140
			20	20	55	140	290	542	1050	1700
			25	22	60	160	330	650	1200	2000
			30	20	55	150	310	600	1100	1900
			35	19	50	140	300	550	1100	1800
			40	20	55	140	290	542	1050	1700
			50	22	60	160	330	650	1200	2000
			60	20	55	150	310	600	1100	1900
Emergency stop torque $T_{2NOT}$	Nm	1,2	3~100 Triple rated output torque							
			Rated input speed $n_{1N}$							
			Maximum input speed $n_{1B}$							
Super precision backlash $P_0$	arcmin	1	3~10							
			15~100							
Precision backlash $P_1$	arcmin	1	3~10							
			15~100							
Standard backlash $P_2$	arcmin	1	3~10							
			15~100							
Torsional rigidity	Nm/arcmin	1,2	3~100							
			780 1530 3250 6700 9400 14500 20000							
Allowable radial force $F_{2aB}$	N	1,2	3~100							
			390 765 1625 3350 4700 7250 10000							
Lifespan	hr	1,2	3~100							
			20000							
Efficiency	%	1	3~10							
			15~100							
Weight	kg	1	3~10							
			15~100							
Use of temperature	°C	1,2	3~100							
			-20°C~+40°C							
Lubricating		1,2	Synthetic lubricating grease							
			IP65							
IP Grade		1,2	3~100							
			In any direction							
Installation direction	dB(A)	1,2	3~100							
			≤56 ≤58 ≤60 ≤63 ≤65 ≤67 ≤70							

# ROTATIONAL INERTIA OF REDUCER

## Rotational inertia

Specification	Unit	Stage	Ratio	WVRB042	WVRB060	WVRB090	WVRB115	WVRB140	WVRB180	WVRB220
Rotational inertia $J_1$	kg · cm <sup>2</sup>	1	3	0.053	0.22	1.2	5.3	20	44	90
			4	0.041	0.17	0.95	4.1	15	28	62
			5	0.036	0.16	0.86	3.6	14	22	52
			6	0.034	0.15	0.82	3.3	13	18	47
			7	0.032	0.14	0.79	3.2	12	16	42
			8	0.031	0.14	0.77	3.1	12	15	40
			10	0.03	0.14	0.75	3	11	14	38
		2	15	0.035	0.14	0.72	2.8	11	12	36
			20	0.034	0.13	0.72	2.8	11	12	35
			25	0.034	0.13	0.71	2.8	11	12	35
			30	0.03	0.13	0.7	2.7	10	11	34
			35	0.034	0.13	0.71	2.7	11	12	35
			40	0.03	0.13	0.7	2.7	10	11	33
			50	0.03	0.13	0.69	2.7	10	11	33
			60	0.03	0.13	0.69	2.7	10	11	33
			70	0.03	0.13	0.69	2.7	10	11	33
			80	0.03	0.13	0.69	2.7	10	11	33
			100	0.03	0.13	0.69	2.7	10	11	33

1. Ratio (  $i = N_{in}/N_{out}$  )

2. Maximum acceleration torque  $T_{2B} = 60\%$  of  $T_{2NOT}$

3. Output speed 100rpm, acting on the center of the output shaft

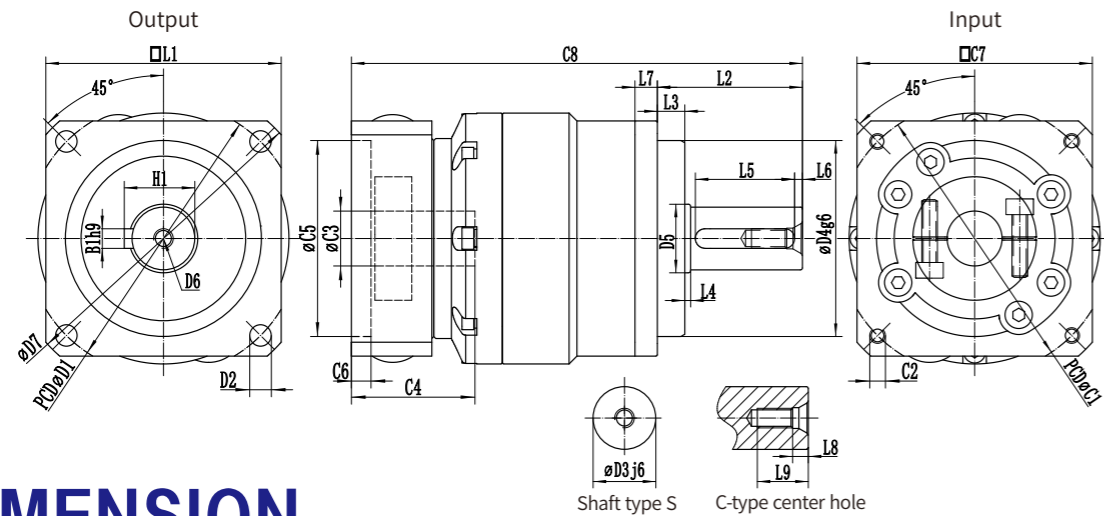

# DIMENSION

## SINGLE SECTION

Dimension(single stage,Ratio i=3~10)

Dimension	WVRB042	WVRB060	WVRB090	WVRB115	WVRB140	WVRB180	WVRB220				
D1	50	70	100	130	165	215	250				
D2	3.5	5.5	6.6	9	11	13.5	17				
D3 j6	13	16	22	32	40	55	75				
D4 g6	35	50	80	110	130	160	180				
D5	15	18	30	40	50	70	85				
D6	M4*0.7P	M5*0.8P	M8*1.25P	M12*1.75P	M16*2.0P	M20*2.5P	M20*2.5P				
D7	57	80	116	152	185	240	290				
L1	42	60	90	115	140	180	220				
L2	26	37	48	60	95	105	138				
L3	5.5	7	10	7	13	20	30				
L4	1	1.5	1.5	2	3	3	3				
L5	16	25	32	40	63	70	90				
L6	2	2	3	5	5	6	7				
L7	4	6	8	10	12	15	20				
L8	3.2	4.8	7.2	10	12	15	15				
L9	10	12.5	19	28	36	42	42				
C1	46	70	70	90	90	145	145	200	200	200	235
C2	M4	M4	M4	M5	M5	M8	M8	M12	M12*1.75P	M12*1.75P	M12*1.75P
C3	≤8	≤11	≤14	≤19	≤19	≤24	≤24	≤35	≤35/≤42	≤42	≤42/≤55
C4	26	31.5	31.5	41	41	59	60	81	81	114	117
C5	30	50	50	70	70	110	110	114.3	114.3	114.3	200
C6	5	5	5	5	6	14	14	19	19	24	20
C7	48	60	60	80	80	130	130	180	180	180	220
C8	86	95	115	128	147	165	199.5	221.5	279	318	377
B1 h9	5	5	6	10	12	16	20				
H1	15	18	24.5	35	43	59	79.5				

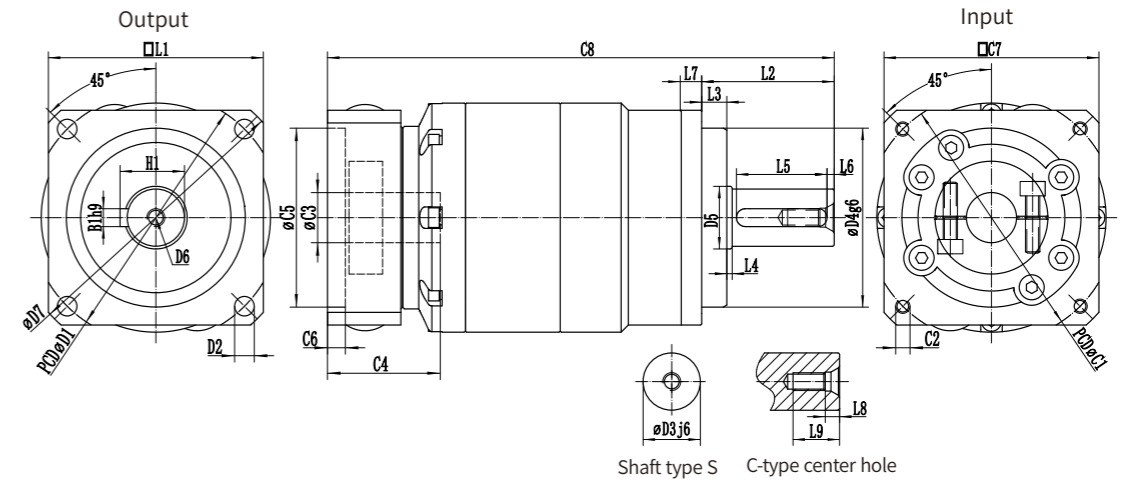

# DIMENSION

## SINGLE SECTION

Dimension(double stage,Ratio i=15~100)

Dimension	WVRB042	WVRB060	WVRB090	WVRB115	WVRB140	WVRB180	WVRB220					
D1	50	70	100	130	165	215	250					
D2	3.5	5.5	6.6	9	11	13.5	17					
D3 j6	13	16	22	32	40	55	75					
D4 g6	35	50	80	110	130	160	180					
D5	15	18	30	40	50	70	85					
D6	M4*0.7P	M5*0.8P	M8*1.25P	M12*1.75P	M16*2.0P	M20*2.5P	M20*2.5P					
D7	57	80	116	152	185	240	290					
L1	42	60	90	115	140	180	220					
L2	26	37	48	60	95	105	138					
L3	5.5	7	10	7	13	20	30					
L4	1	1.5	1.5	2	3	3	3					
L5	16	25	32	40	63	70	90					
L6	2	2	3	5	5	6	7					
L7	4	7	8	10	12	15	20					
L8	3.2	4.8	7.2	10	12	15	15					
L9	10	12.5	19	28	36	42	42					
C1	46	70	70	90	90	145	145	200	200	200	235	
C2	M4	M4	M4	M5	M4	M5	M8	M5	M8	M8*1.25P	M12*1.75P	M12*1.75P
C3	≤8	≤11	≤14	≤19	≤14	≤19	≤24	≤19	≤24	≤24/≤28	≤35	≤42
C4	26	31.5	31.5	41	31.5	41	59	41	60	66	80	114
C5	30	50	50	70	50	70	110	70	110	110	114.3	114.3
C6	5	5	5	5	5	6	14	6	14	10	9	24
C7	48	60	60	80	60	80	130	80	130	130	180	180
C8	107	116	147	160	168	184.5	202.5	214	244.5	325	352.5	441.5
B1 h9	5	5	6	10	12	16	20					
H1	15	18	24.5	35	43	59	79.5					

# WAE Series Planetary Gearbox

## FEATURES

- » The planet gear carrier and output end adopt an integrated double-supported structure design to ensure maximum torsional rigidity, toughness, and rotational accuracy.
- » The planet gear adopts a full needle roller design to increase the contact area and improve the structural rigidity and output torque.
- » The gear uses low carbon steel carburized and quenched to achieve a surface hardness of HRC62 to obtain the best wear resistance and impact toughness.
- » The gear profile is designed with assistance from imported software to obtain the best possible design, thereby reducing noise.
- » The connection between the input end and the motor shaft adopts a double-sided clamping method to achieve maximum clamping force and zero backlash power transmission.



## SELECTION

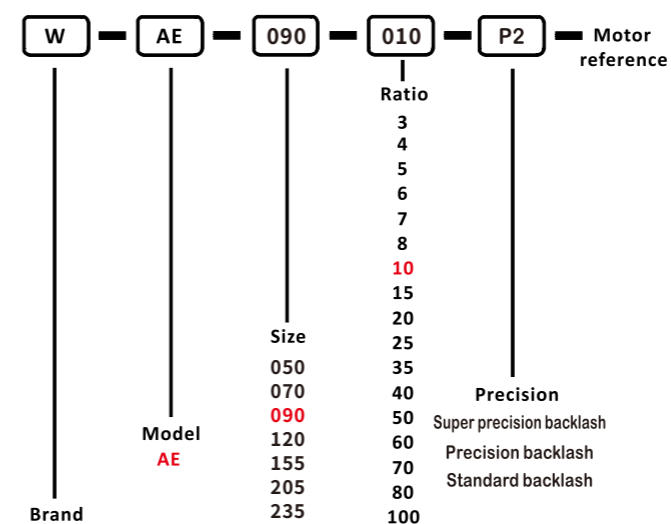

## GENERAL NOTICES

- Type, model and torque
- Ratio or output speed
- Working conditions and connection methods
- Quantity and installed machine name
- Input mode and input speed
- Motor brand model or flange and motor shaft size

# PLANETARY GEARBOX

## Performance

Specification	Unit	Stage	Ratio	WAE050	WAE070	WAE090	WAE120	WAE155	WAE205	WAE235
Rated output torque $T_{2N}$	Nm	1	3	20	55	130	208	342	588	1140
			4	19	50	140	290	542	1050	1700
			5	22	60	160	330	650	1200	2000
			6	20	55	150	310	600	1100	1900
			7	19	50	140	300	550	1100	1800
			8	17	45	120	260	500	1000	1600
			10	14	40	100	230	450	900	1500
			15	20	55	130	208	342	588	1140
			20	19	50	140	290	542	1050	1700
		2	25	22	60	160	330	650	1200	2000
			30	20	55	150	310	600	1100	1900
			35	19	50	140	300	550	1100	1800
			40	19	50	140	290	542	1050	1700
			50	22	60	160	330	650	1200	2000
			60	20	55	150	310	600	1100	1900
			70	19	50	140	300	550	1100	1800
			80	17	45	120	260	500	1000	1600
			100	14	40	100	230	450	900	1500
Emergency stop torque $T_{2NOT}$	Nm	1,2	3~100	Triple rated output torque						
Rated input speed $n_{1N}$	rpm	1,2	3~100	5000	5000	4000	4000	3000	3000	2000
Maximum input speed $n_{1B}$	rpm	1,2	3~100	10000	10000	8000	8000	6000	6000	4000
Super precision backlash $P_0$	arcmin	1	3~10	-	≤1.5	≤1.5	≤1.5	≤1.5	≤1.5	≤1.5
		2	15~100	-	≤3	≤3	≤3	≤3	≤3	≤3
Precision backlash $P_1$	arcmin	1	3~10	-	≤3	≤3	≤3	≤3	≤3	≤3
		2	15~100	-	≤5	≤5	≤5	≤5	≤5	≤5
Standard backlash $P_2$	arcmin	1	3~10	≤12	≤5	≤5	≤5	≤5	≤5	≤5
		2	15~100	≤16	≤8	≤8	≤8	≤8	≤8	≤8
Torsional rigidity	Nm/arcmin	1,2	3~100	3	7	14	25	50	145	225
Allowable radial force $F_{2aB}$	N	1,2	3~100	780	1530	3250	6700	9400	14500	20000
Allowable axial force $F_{2aB}$	N	1,2	3~100	390	765	1625	3350	4700	7250	10000
Lifespan	hr	1,2	3~100	20000						
Efficiency	%	1	3~10	≥97%						
		2	15~100	≥94%						
Weight	kg	1	3~10	0.6	1.2	3.7	7.5	16	36	53
		2	15~100	0.7	1.6	4.2	10.7	17	37	54
Use of temperature	°C	1,2	3~100	-20°C~+40°C						
Lubricating		1,2	Synthetic lubricating grease							
IP Grade		1,2	3~100	IP65						
Installation direction		1,2	3~100	In any direction						
Noise level ( $n_1=3000$ rpm, off load)	dB(A)	1,2	3~100	≤56	≤58	≤60	≤63	≤65	≤67	≤70

# ROTATIONAL INERTIA OF REDUCER

## Rotational inertia

Specification	Unit	Stage	Ratio	WAE050	WAE070	WAE090	WAE120	WAE155	WAE205	WAE235
Rotational inertia $J_1$	kg · cm <sup>2</sup>	1	3	0.03	0.16	0.61	3.25	9.21	28.98	69.61
			4	0.03	0.14	0.48	2.74	7.54	23.67	54.37
			5	0.03	0.13	0.47	2.71	7.42	23.29	53.27
			6	0.03	0.13	0.45	2.65	7.25	22.75	51.72
			7	0.03	0.13	0.45	2.62	7.14	22.48	50.97
			8	0.03	0.13	0.44	2.58	7.07	22.59	50.84
			10	0.03	0.13	0.44	2.57	7.03	22.51	50.56
			15	0.03	0.03	0.13	0.47	2.71	7.42	23.29
			20	0.03	0.03	0.13	0.47	2.71	7.42	23.29
		2	25	0.03	0.03	0.13	0.47	2.71	7.42	23.29
			30	0.03	0.03	0.13	0.47	2.71	7.42	23.29
			35	0.03	0.03	0.13	0.47	2.71	7.42	23.29
			40	0.03	0.03	0.13	0.47	2.71	7.42	23.29
			50	0.03	0.03	0.13	0.44	2.57	7.03	22.51
			60	0.03	0.03	0.13	0.44	2.57	7.03	22.51
			70	0.03	0.03	0.13	0.44	2.57	7.03	22.51
			80	0.03	0.03	0.13	0.44	2.57	7.03	22.51
			100	0.03	0.03	0.13	0.44	2.57	7.03	22.51

1. Ratio ( $i=N_{in}/N_{out}$ )

2. Maximum acceleration torque  $T_{2B}=60\%$  of  $T_{2NOT}$

3. Output speed 100rpm, acting on the center of the output shaft



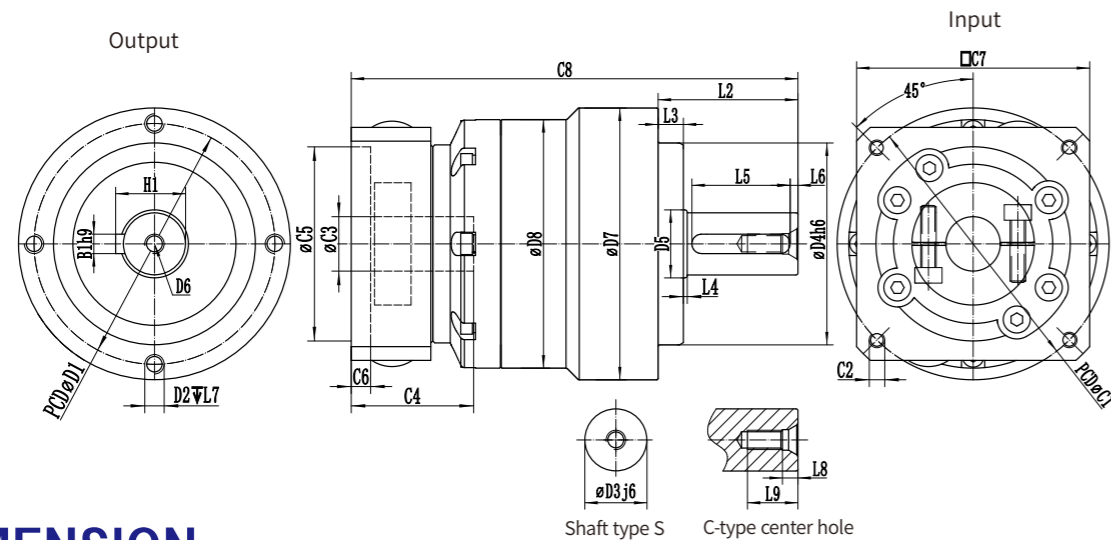

### DIMENSION SINGLE SECTION

Dimension(single stage,Ratio i=3~10)

Dimension	WAE050	WAE070	WAE090	WAE120	WAE155	WAE205	WAE235
D1	44	62	80	108	140	184	210
D2	M4*0.7P	M5*0.8P	M6*1.0P	M8*1.25P	M10*1.5P	M12*1.75P	M16*2.0P
D3 j6	12	16	22	32	40	55	75
D4 g6	35	52	68	90	120	160	180
D5	15	18	30	40	50	70	85
D6	M4*0.7P	M5*0.8P	M8*1.25P	M12*1.75P	M16*2.0P	M20*2.5P	M20*2.5P
D7	50	70	90	120	155	205	235
D8	53	64	94	125	150	200	225
L1	-	-	-	-	-	-	-
L2	24.5	36	46	70	97	100	126
L3	4	6.5	8	17	15	15	18
L4	1	1	1	1.5	3	3	3
L5	14	25	32	40	63	70	90
L6	2	2	3	5	5	6	7
L7	10	10	12	16	20	22	28
L8	3.2	4.8	7.2	10	12	15	15
L9	10	12.5	19	28	36	42	42
C1	46	70	90	90	145	145	200
C2	M4*0.7P	M4	M5	M5	M8	M8	M12
C3	≤8	≤14	≤19	≤19	≤24	≤24	≤35
C4	26	31.5	41	41	59	60	81
C5	30	50	70	70	110	110	114.3
C6	5	5	5	6	14	14	19
C7	42	60	80	80	130	130	180
C8	86	115	128	147	165	199.5	221.5
B1 h9	4	5	6	10	12	16	20
H1	13.5	18	24.5	35	43	59	79.5

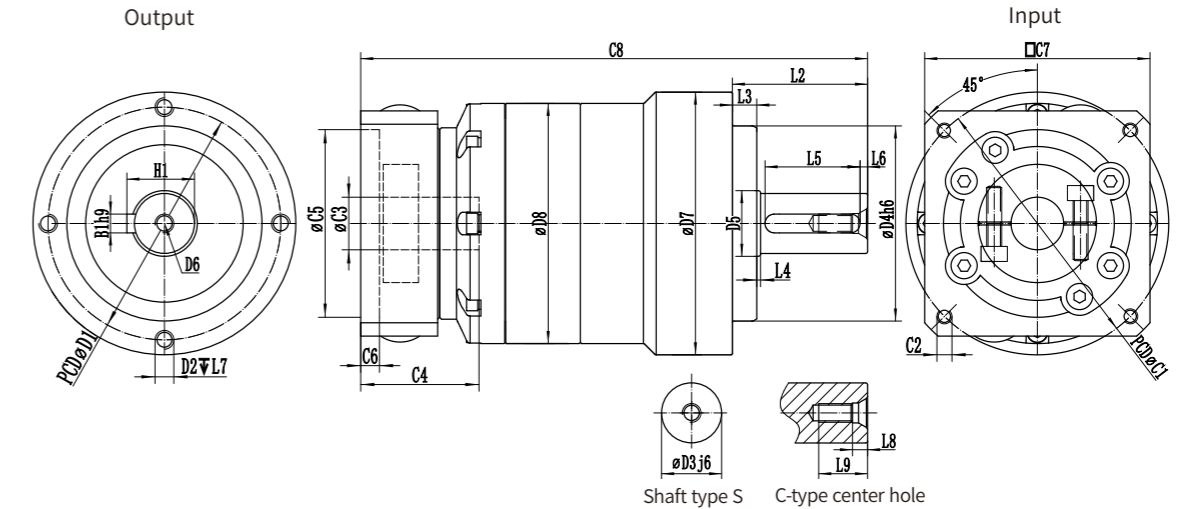

### DIMENSION DOUBLE SECTION

Dimension(double stage,Ratio i=15~100)

Dimension	WAE050	WAE070	WAE090	WAE120	WAE155	WAE205	WAE235
D1	44	62	80	108	140	184	210
D2	M4*0.7P	M5*0.8P	M6*1.0P	M8*1.25P	M10*1.5P	M12*1.75P	M16*2.0P
D3 j6	12	16	22	32	40	55	75
D4 g6	35	52	68	90	120	160	180
D5	15	18	30	40	50	70	85
D6	M4*0.7P	M5*0.8P	M8*1.25P	M12*1.75P	M16*2.0P	M20*2.5P	M20*2.5P
D7	50	70	90	120	155	205	235
D8	53	64	94	125	150	200	225
L1	-	-	-	-	-	-	-
L2	24.5	36	46	70	97	100	126
L3	4	6.5	8	17	15	15	18
L4	1	1	1	1.5	3	3	3
L5	14	25	32	40	63	70	90
L6	2	2	3	5	5	6	7
L7	10	10	12	16	20	22	28
L8	3.2	4.8	7.2	10	12	15	15
L9	10	12.5	19	28	36	42	42
C1	46	70	90	90	145	145	200
C2	M4*0.7P	M4	M5	M4	M5	M8	M5
C3	≤8	≤14	≤19	≤14	≤19	≤24	≤19
C4	26	31.5	41	31.5	41	59	41
C5	30	50	70	50	70	110	70
C6	5	5	5	5	6	14	6
C7	42	60	80	60	80	130	80
C8	107	147	160	168	184.5	202.5	214
B1 h9	4	5	6	10	12	16	20
H1	13.5	18	24.5	35	43	59	79.5

# WADR Series Planetary Gearbox

## FEATURES

- » Planet gear carrier and output shaft are integrated structure designed to ensure maximum torsional rigidity.
- » Planet gear with full needle design, increase the contact area to improve the rigidity and output torque.
- » The gears are carburized and quenched to the HRC62 with low carbon steel surface for optimum wear and impact toughness.
- » Gears refer to foreign imported software-assisted design to obtain the best tooth shape to reduce noise.
- » Adopt spiral bevel gear design, allow high output torque, more than 30% higher than straight bevel gear.
- » High allowable input speed, more than 8 times higher than straight bevel gear input.
- » The meshing tooth imprint of spiral bevel gear has been optimized by optimum design, thus ensuring even load on the contact tooth surface and a long service life.
- » Spiral bevel gears are meshed by optimum motion error analysis and strict process control to ensure high precision running backlash.



## SELECTION

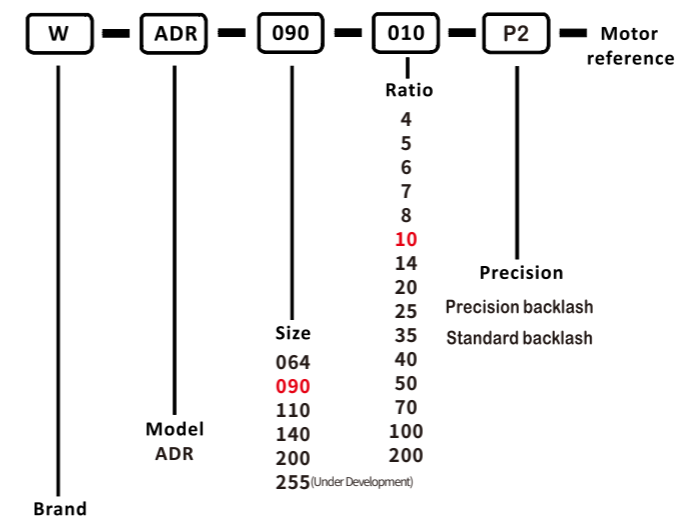

## GENERAL NOTICES

- Type, model and torque
- Ratio or output speed
- Working conditions and connection methods
- Quantity and installed machine name
- Input mode and input speed
- Motor brand model or flange and motor shaft size

# PLANETARY GEARBOX

## Performance

Specification	Unit	Stage	Ratio	WADR064	WADR090	WADR110	WADR140	WADR200	WADR255
Rated output torque $T_{2N}$	Nm	1	4	48	130	270	560	1100	-
			5	60	160	330	650	1200	-
			6	50	140	300	550	1100	-
			7	50	140	300	550	1100	-
			8	48	130	270	560	1100	-
			10	60	160	330	650	1200	-
			14	50	140	300	550	1100	-
		2	20	40	100	230	450	900	-
			25	60	160	330	650	1200	-
			35	50	140	300	550	1100	-
			40	48	130	270	560	1100	-
			50	60	160	330	650	1200	-
			70	50	140	300	550	1100	-
			100	60	160	330	650	1200	-
			140	50	140	300	550	1100	-
			200	40	100	230	450	900	-
Emergency stop torque $T_{2NOT}$	Nm	1,2	4~200	Triple rated output torque					
Rated input speed $n_{1N}$	rpm	1,2	4~200	5000	4000	4000	3000	3000	-
Maximum input speed $n_{1B}$	rpm	1,2	4~200	10000	8000	8000	6000	6000	-
Precision backlash $P_1$	arcmin	1	4~20	≤5	≤5	≤5	≤5	≤5	-
		2	25~200	≤7	≤7	≤7	≤7	≤7	-
Standard backlash $P_2$	arcmin	1	4~20	≤7	≤7	≤7	≤7	≤7	-
		2	25~200	≤10	≤10	≤10	≤10	≤10	-
Torsional rigidity	Nm/arcmin	1,2	4~200	13	31	82	151	440	-
Maximum bending torque $M_{2KB}$	Nm	1,2	4~200	125	235	430	1300	3064	-
Allowable axial force $F_{2aB}$	N	1,2	4~200	1050	2850	2990	10590	16660	-
Lifespan	hr	1,2	4~200	20000					
Efficiency	%	1		≥95%					
		2		≥92%					
Weight	kg	1	4~20	1.9	4.5	9.8	20.1	46.6	-
		2	25~200	2.1	5.9	10.5	21.9	53.9	-
Use of temperature	°C	1,2	4~200	-20°C~+40°C					
Lubricating				Synthetic lubricating grease					
IP Grade		1,2	4~200	IP65					
Installation direction		1,2	4~200	In any direction					
Noise level ( $n_1=3000\text{rpm}$ , off load)	dB(A)	1,2	4~200	≤63	≤65	≤68	≤70	≤72	-

## Rotational inertia

Specification	Unit	Stage	Ratio	WADR064	WADR090	WADR110	WADR140	WADR200	WADR255
Rotational inertia $J_1$	kg·cm²	1	4~10	0.35	2.25	6.84	23.4	-	-
			14	0.07	1.87	6.25	21.8	-	-
			20	0.07	1.87	6.25	21.8	-	-
		2	25~100	0.09	0.35	2.25	6.84	-	-
			140~200	-	0.31	1.87	6.25	-	-

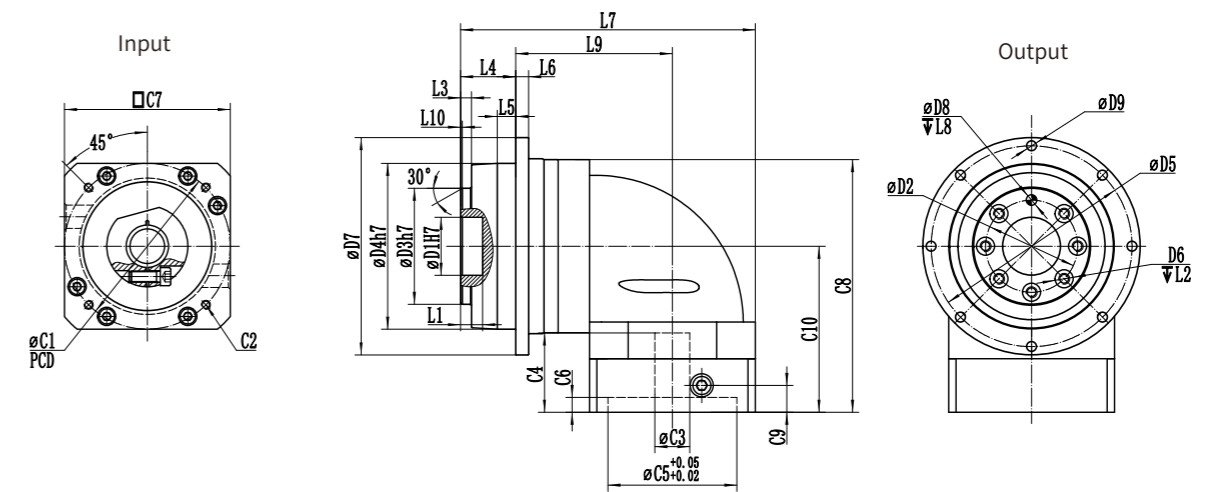

## DIMENSION SINGLE SECTION

Dimension(single stage, Ratio i=4~20)

Dimension	WADR064	WADR090	WADR110	WADR140	WADR200	WADR255
D1H7	20	31.5	40	50	80	-
D2	31.5	50	63	80	125	-
D3h7	40	63	80	100	160	-
D4h7	64	90	110	140	200	-
D5	79	109	135	168	233	-
D6	7-M5	7-M6	11-M6	11-M8	11-M10	-
D7	86	118	145	179	247	-
D8H7	5	6	6	8	10	-
D9	8-4.5	8-5.5	8-5.5	12-6.6	12-9	-
L1	8	12	12	12	16	-
L2	9	12	12	17	23	-
L3	3	6	6	6	8	-
L4	19.5	30	29	38	50	-
L5	7	10	10	14.6	15	-
L6	4	7	8	10	12	-
L7	113.2	160	187	241.5	301.5	-
L8	6	7	7	7	10	-
L9	63.7	85	100.5	132.5	161.5	-
L10	0.5	1	1	1	1.5	-
C1	70	90	145	200	200	-
C2	4-M4	4-M5	4-M8	4-M12	4-M12	-
C3	14	19	24	35	42	-
C4	35	43	71	86	119	-
C5	50	70	110	114.3	114.3	-
C6	5	8	14	19	15	-
C7	60	90	130	180	180	-
C8	103.9	137.1	189	237.5	300.5	-
C9	11.5	14.5	27	32	65	-
C10	71.9	90.1	126.5	162.5	162.5	-

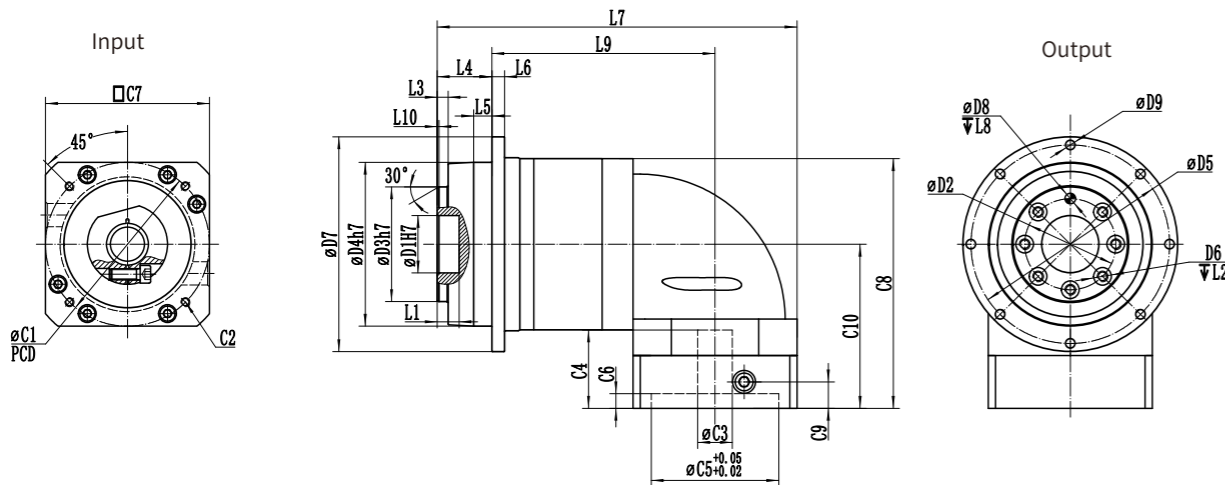

## DIMENSION

### SINGLE SECTION

Dimension(double stage,Ratio i=25~200)

Dimension	WADR064	WADR090	WADR110	WADR140	WADR200	WADR255
D1H7	20	31.5	40	50	80	-
D2	31.5	50	63	80	125	-
D3h7	40	63	80	100	160	-
D4h7	64	90	110	140	200	-
D5	79	109	135	168	233	-
D6	7-M5	7-M6	11-M6	11-M8	11-M10	-
D7	86	118	145	179	247	-
D8H7	5	6	6	8	10	-
D9	8-4.5	8-5.5	8-5.5	12-6.6	12-9	-
L1	8	12	12	12	16	-
L2	9	12	12	17	23	-
L3	3	6	6	6	8	-
L4	19.5	30	29	38	50	-
L5	7	10	10	14.6	15	-
L6	4	7	8	10	12	-
L7	145.2	197.5	232	302.5	339	-
L8	6	7	7	7	10	-
L9	95.7	122.5	145.5	193.5	199	-
L10	0.5	1	1	1	1.5	-
C1	70	90	145	200	200	-
C2	4-M4	4-M5	4-M8	4-M12	4-M12	-
C3	14	19	24	35	42	-
C4	35	43	71	86	119	-
C5	50	70	110	114.3	114.3	-
C6	5	8	14	19	15	-
C7	60	90	130	180	180	-
C8	103.9	137.1	189	237.5	300.5	-
C9	11.5	14.5	27	32	65	-
C10	71.9	90.1	126.5	162.5	162.5	-

# WRBR Series Planetary Gearbox

## FEATURES

- » Planet gear carrier and output shaft are integrated structure designed to ensure maximum torsional rigidity.
- » Planet gear with full needle design, increase the contact area to improve the rigidity and output torque.
- » The gears are carburized and quenched to the HRC62 with low carbon steel surface for optimum wear and impact toughness.
- » Gears refer to foreign imported software-assisted design to obtain the best tooth shape to reduce noise.
- » Adopt spiral bevel gear design, allow high output torque, more than 30% higher than straight bevel gear.
- » High allowable input speed, more than 8 times higher than straight bevel gear input.
- » The meshing tooth imprint of spiral bevel gear has been optimized by optimum design, thus ensuring even load on the contact tooth surface and a long service life.
- » Spiral bevel gears are meshed by optimum motion error analysis and strict process control to ensure high precision running backlash.



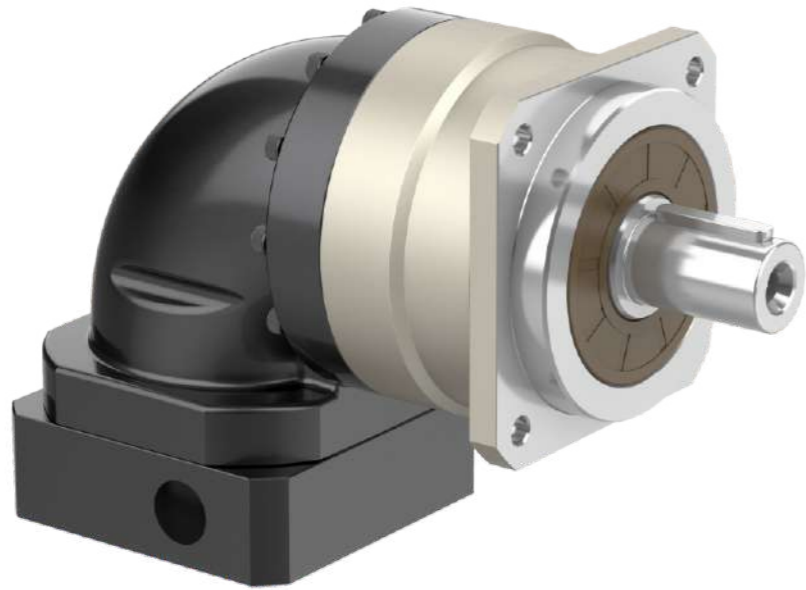

## SELECTION

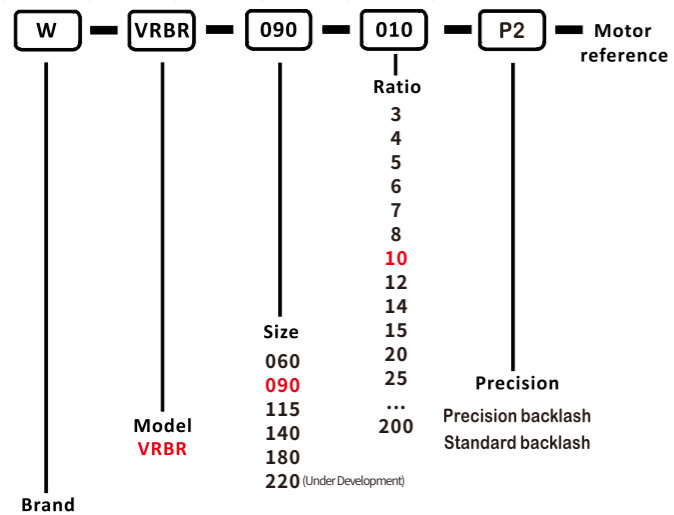

## GENERAL NOTICES

- Type, model and torque
- Ratio or output speed
- Working conditions and connection methods
- Quantity and installed machine name
- Input mode and input speed
- Motor brand model or flange and motor shaft size

## Performance

Specification	Unit	Stage	Ratio	WRBR060	WRBR090	WRBR115	WRBR140	WRBR180	WRBR220
Rated output torque $T_{2N}$	Nm	1	3	55	130	208	342	588	-
			4	50	140	290	540	1050	-
			5	60	160	330	650	1200	-
			6	55	150	310	600	1100	-
			7	50	140	300	550	1100	-
			8	50	140	290	542	1050	-
			10	60	160	330	650	1200	-
			12	55	150	310	600	1100	-
			14	50	140	300	550	1100	-
			20	40	100	230	450	900	-
		2	15	55	130	208	342	588	-
			25	60	160	330	650	1200	-
			30	55	130	208	342	588	-
			35	50	140	300	550	1100	-
			40	50	140	290	542	1050	-
			50	60	160	330	650	1200	-
			60	55	150	310	600	1100	-
			70	50	140	300	550	1100	-
			80	50	140	290	542	1050	-
			100	60	160	330	650	1200	-
Emergency stop torque $T_{2NOT}$	Nm	1,2	3~200	Triple rated output torque					-
		1,2	3~200	5000	4000	4000	3000	3000	-
Rated input speed $n_{1N}$	rpm	1,2	3~200	10000	8000	8000	6000	6000	-
Maximum iutput speed $n_{1B}$	rpm	1,2	3~200	10000	8000	8000	6000	6000	-
Precision backlash $P_1$	arcmin	1	3~20	≤5	≤5	≤5	≤5	≤5	-
		2	15~200	≤7	≤7	≤7	≤7	≤7	-
Standard backlash $P_2$	arcmin	1	3~20	≤7	≤7	≤7	≤7	≤7	-
		2	15~200	≤10	≤10	≤10	≤10	≤10	-
Torsional rigidity	Nm/arcmin	1,2	3~200	7	14	25	50	145	-
Allowable radial force $F_{2aB}$	N	1,2	3~200	1530	3250	6700	9400	14500	-
Allowable axial force $F_{2aB}$	N	1,2	3~200	765	1625	3350	4700	7250	-
Lifespan	hr	1,2	3~200	20000					-
Efficiency	%	1	3~20	95%					-
		2	25~200	92%					-
Weight	kg	1	3~20	2.1	6.4	13	24.5	51	-
		2	25~200	1.5	7.8	14.2	27.5	54	-
Use of temperature	°C	1,2	3~200	-20°C~+40°C					-
Lubricating		Synthetic lubricating grease							
IP Grade		1,2	3~200	IP65					-
Installation direction		3~200 In any direction							
Noise level (n1=3000, off load)	dB(A)	1,2	3~200	≤63	≤65	≤68	≤70	≤72	-

## Rotational inertia

Specification	Unit	Stage	Ratio	WRBR060	WRBR090	WRBR115	WRBR140	WRBR180	WRBR220
Rotational inertia $J_1$	kg.cm <sup>2</sup>	1	3~10	0.35	2.25	6.84	23.4	68.9	-
			12~14	0.07	1.87	6.25	21.8	65.6	-
			20	0.07	1.87	6.25	21.8	65.6	-
		2	15	0.35	2.25	6.84	23.4	68.9	-
			25~100	0.09	0.35	2.25	6.84	23.4	-
			120~200	0.01	0.31	1.87	6.25	21.8	-

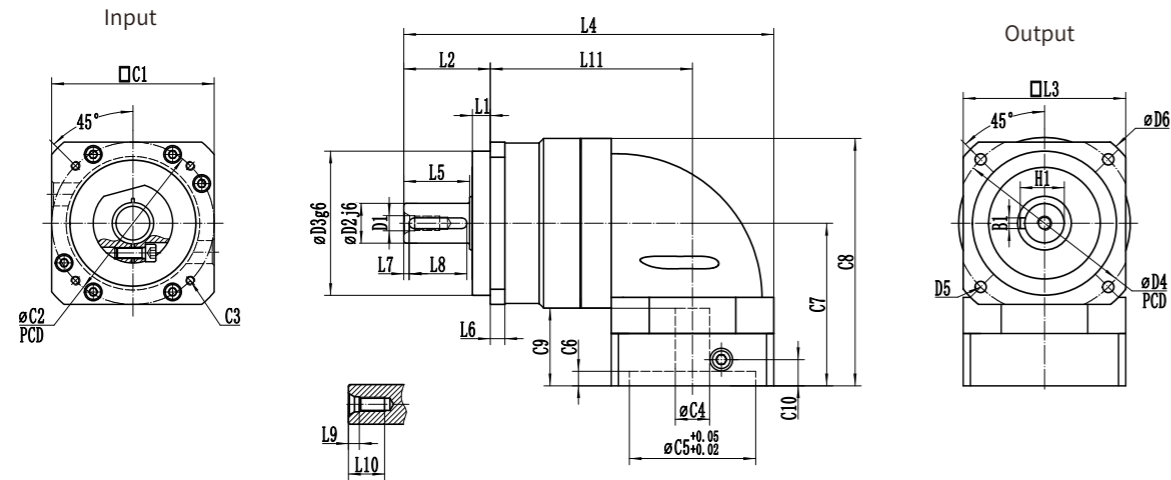

## DIMENSION

### DOUBLE SECTION

Dimension(single stage,Ratio i=3~20)

Dimension	WVRBR060	WVRBR090	WVRBR115	WVRBR140	WVRBR180	WVRBR220
D1	M5	M8	M12	M16	M20	-
D2j6	16	22	32	40	55	-
D3g6	50	80	110	130	160	-
D4	70	100	130	165	215	-
D5	4-5.5	4-6.6	4-9	4-11	4-13.5	-
D6	80	116	152	185	240	-
L1	7	10	7	13	20	-
L2	37	48	60	95	105	-
L3	60	90	115	140	180	-
L4	152.2	205	259	347	394	-
L5	28.5	36.5	51	79	82	-
L6	6	8	10	12	15	-
L7	2	3	5	5	6	-
L8	25	32	40	63	70	-
L9	4	6	10	12	11.5	-
L10	13	20	28	36	42	-
L11	85.2	112	141.5	181	199	-
C1	60	90	130	180	180	-
C2	70	90	145	200	200	-
C3	4-M4	4-M5	4-M8	4-M12	4-M12	-
C4	14	19	24	35	42	-
C5	50	70	110	114.3	114.3	-
C6	5	8	14	19	15	-
C7	71.9	90.1	126.5	162.5	195.5	-
C8	103.9	137.1	189	237.5	295.5	-
C9	35	43	71	86	119	-
C10	11.5	14.5	27	32	65	-
B1	5	6	10	12	16	-
H1	18	24.5	35	43	59	-

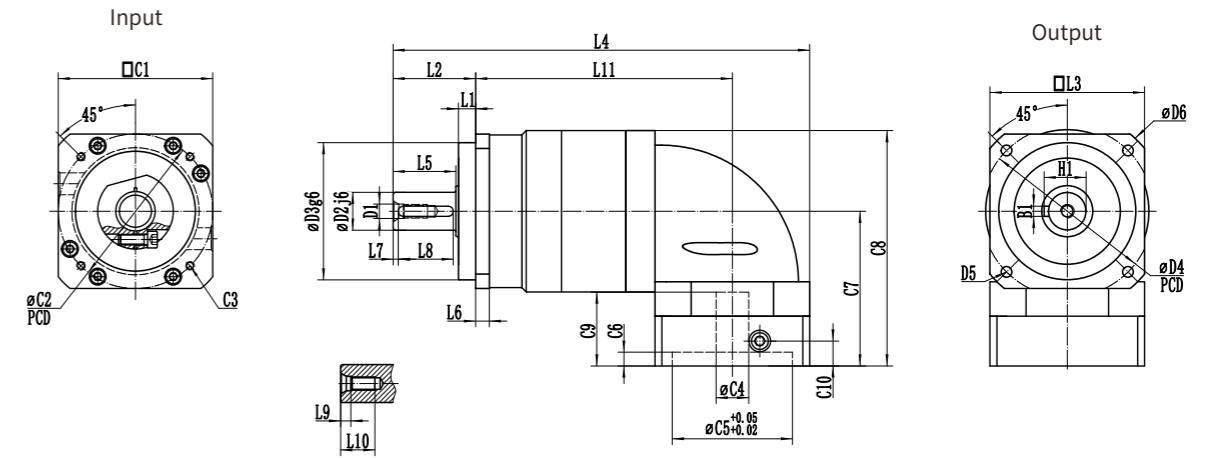

## DIMENSION

### DOUBLE SECTION

Dimension(double stage,Ratio i=15~200)

Dimension	WVRBR060	WVRBR090	WVRBR115	WVRBR140	WVRBR180	WVRBR220
D1	M5	M8	M12	M16	M20	-
D2j6	16	22	32	40	55	-
D3g6	50	80	110	130	160	-
D4	70	100	130	165	215	-
D5	4-5.5	4-6.6	4-9	4-11	4-13.5	-
D6	80	116	152	185	240	-
L1	7	10	7	13	20	-
L2	37	48	60	95	105	-
L3	60	90	115	140	180	-
L4	184.2	242.5	304	408	431.5	-
L5	28.5	36.5	51	79	82	-
L6	6	8	10	12	15	-
L7	2	3	5	5	6	-
L8	25	32	40	63	70	-
L9	4	6	10	12	11.5	-
L10	13	20	28	36	42	-
L11	117.2	149.5	186.5	242	236.5	-
C1	60	90	130	180	180	-
C2	70	90	145	200	200	-
C3	4-M4	4-M5	4-M8	4-M12	4-M12	-
C4	14	19	24	35	42	-
C5	50	70	110	114.3	114.3	-
C6	5	8	14	19	15	-
C7	71.9	90.1	126.5	162.5	195.5	-
C8	103.9	137.1	189	237.5	295.5	-
C9	35	43	71	86	119	-
C10	11.6	14.5	27	32	65	-
B1	5	6	10	12	16	-
H1	18	24.5	35	43	59	-

# WAER Series Planetary Gearbox

## FEATURES

- » Planet gear carrier and output shaft are integrated structure designed to ensure maximum torsional rigidity.
- » Planet gear with full needle design, increase the contact area to improve the rigidity and output torque.
- » The gears are carburized and quenched to the HRC62 with low carbon steel surface for optimum wear and impact toughness.
- » Gears refer to foreign imported software-assisted design to obtain the best tooth shape to reduce noise.
- » Adopt spiral bevel gear design, allow high output torque, more than 30% higher than straight bevel gear.
- » High allowable input speed, more than 8 times higher than straight bevel gear input.
- » The meshing tooth imprint of spiral bevel gear has been optimized by optimum design, thus ensuring even load on the contact tooth surface and a long service life.
- » Spiral bevel gears are meshed by optimum motion error analysis and strict process control to ensure high precision running backlash.



## SELECTION

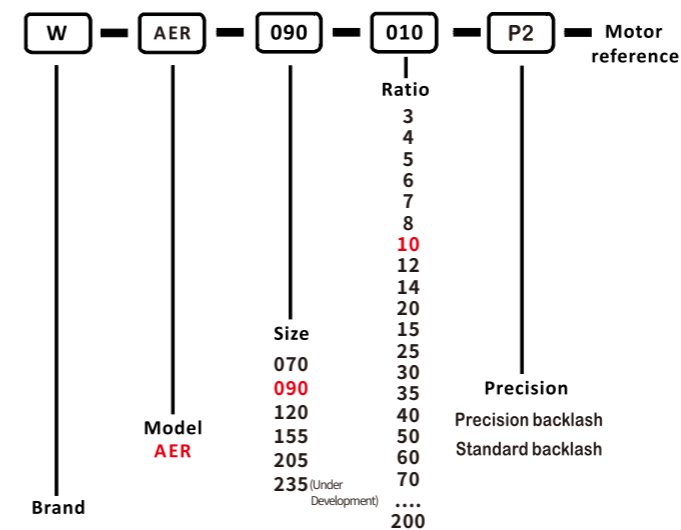

## GENERAL NOTICES

- Type, model and torque
- Ratio or output speed
- Working conditions and connection methods
- Quantity and installed machine name
- Input mode and input speed
- Motor brand model or flange and motor shaft size

Performance

Specification	Unit	Stage	Ratio	WAER070	WAER090	WAER120	WAER155	WAER205	WAER235	
Rated output torque $T_{2N}$	Nm	1	3	55	130	208	342	588	-	-
			4	50	140	290	540	1050	-	-
			5	60	160	330	650	1200	-	-
			6	55	150	310	600	1100	-	-
			7	50	140	300	550	1100	-	-
			8	50	140	290	542	1050	-	-
			10	60	160	330	650	1200	-	-
			12	55	150	310	600	1100	-	-
			14	50	140	300	550	1100	-	-
			20	40	100	230	450	900	-	-
		2	15	55	130	208	342	588	-	-
			25	60	160	330	650	1200	-	-
			30	55	130	208	342	588	-	-
			35	50	140	300	550	1100	-	-
			40	50	140	290	542	1050	-	-
			50	60	160	330	650	1200	-	-
			60	55	150	310	600	1100	-	-
			70	50	140	300	550	1100	-	-
			80	50	140	290	542	1050	-	-
			100	60	160	330	650	1200	-	-
Emergency stop torque $T_{2NOT}$	Nm	1,2	3~200	Triple rated output torque						
		1,2	3~200	5000	4000	4000	3000	3000	-	
Rated input speed $n_{1N}$	rpm	1,2	3~200	5000	4000	4000	3000	3000	-	
Maximum input speed $n_{1B}$	rpm	1,2	3~200	10000	8000	8000	6000	6000	-	
Precision backlash $P_1$	arcmin	1	3~20	≤5	≤5	≤5	≤5	≤5	-	
		2	15~200	≤7	≤7	≤7	≤7	≤7	-	
Standard backlash $P_2$	arcmin	1	3~20	≤7	≤7	≤7	≤7	≤7	-	
		2	15~200	≤10	≤10	≤10	≤10	≤10	-	
Torsional rigidity	Nm/arcmin	1,2	3~200	7	14	25	50	145	-	
Allowable radial force $F_{2aB}$	N	1,2	3~200	1530	3250	6700	9400	14500	-	
Allowable axial force $F_{2aB}$	N	1,2	3~200	765	1625	3350	4700	7250	-	
Lifespan	hr	1,2	3~200	20000						
Efficiency	%	1	3~20	95%						
		2	25~200	92%						
Weight	kg	1	3~20	2.1	6.4	13	24.5	51	-	
		2	25~200	1.5	7.8	14.2	27.5	54	-	
Use of temperature	°C	1,2	3~200	-20°C~+40°C						
Lubricating				Synthetic lubricating grease						
IP Grade		1,2	3~200	IP65						
Installation direction			3~200	In any direction						
Noise level ( $n_1=3000$ , off load)	dB(A)	1,2	3~200	≤63	≤65	≤68	≤70	≤72	-	

Rotational inertia

Specification	Unit	Stage	Ratio	WAER070	WAER090	WAER120	WAER155	WAER205	WAER235
Rotational inertia $J_1$	kg.cm <sup>2</sup>	1	3~10	0.35	2.25	6.84	23.4	68.9	-
			12、14	0.07	1.87	6.25	21.8	65.6	-
			20	0.07	1.87	6.25	21.8	65.6	-
		2	15	0.35	2.25	6.84	23.4	68.9	-
			25~100	0.09	0.35	2.25	6.84	23.4	-
			0.007	0.01	0.31	1.87	6.25	21.8	-

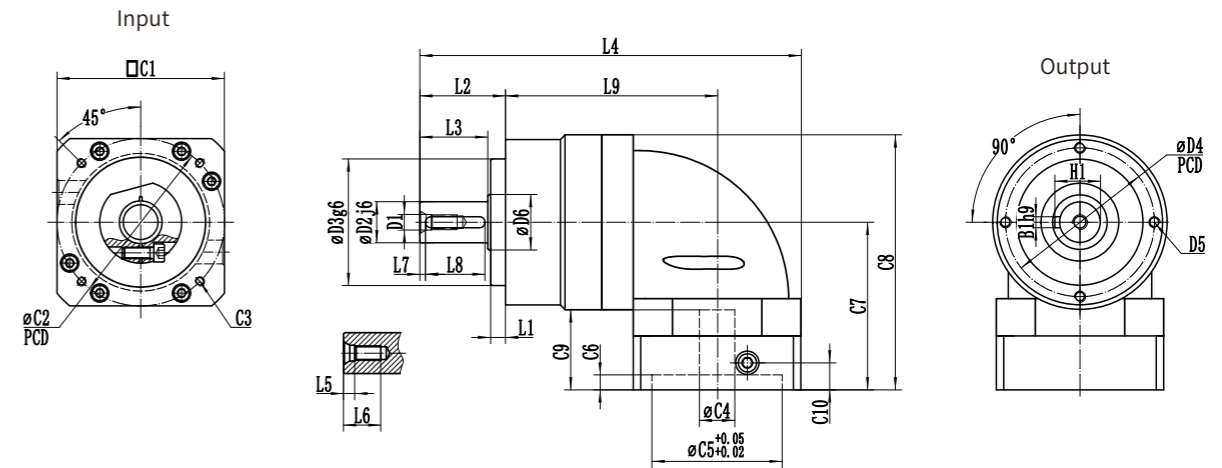

DIMENSION  
SINGLE SECTION

Dimension(single stage, Ratio i=3~200)

Dimension	WAER070	WAER090	WAER120	WAER155	WAER205	WAER235
D1	M5	M8	M12	M16	M16	-
D2j6	16	22	32	40	55	-
D3g6	52	68	90	120	160	-
D4	62	80	108	140	184	-
D5	4-M5	4-M6	4-M8	4-M10	4-M12	-
D6	17.5	29.8	39.5	49.5	69.5	-
L1	6.5	8	17	15	15	-
L2	36	46	70	97	100	-
L3	28.5	36.5	51	79	82	-
L4	152.2	205	259	347	394	-
L5	4	6	10	12	11.5	-
L6	13	20	28	36	42	-
L7	2	3	5	5	6	-
L8	25	32	40	63	70	-
L9	86.2	114	131.5	179	204	-
C1	60	90	130	180	180	-
C2	70	90	145	200	200	-
C3	4-M4	4-M5	4-M8	4-M12	4-M12	-
C4	14	19	24	35	42	-
C5	50	70	110	114.3	114.3	-
C6	5	8	14	19	15	-
C7	71.9	90.1	126.5	162.5	195.5	-
C8	106.9	137.1	189	237.5	295.5	-
C9	35	43	71	86	119	-
C10	11.5	14.5	27	32	65	-
B1	5	6	10	12	16	-
H1	18	24.5	35	43	59	-



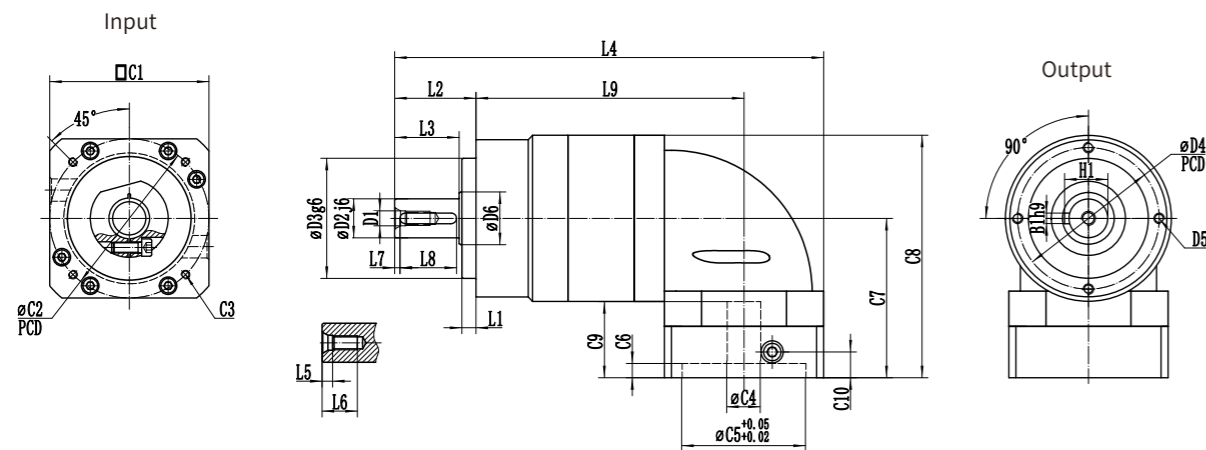

## DIMENSION

### SINGLE SECTION

Dimension(double stage,Ratio i=15~200)

Dimension	WAER070	WAER090	WAER120	WAER155	WAER205	WAER235
D1	M5	M8	M12	M16	M16	-
D2j6	16	22	32	40	55	-
D3g6	52	68	90	120	160	-
D4	62	80	108	140	184	-
D5	4-M5	4-M6	4-M8	4-M10	4-M12	-
D6	17.5	29.8	39.5	49.5	69.5	-
L1	6.5	8	17	15	15	-
L2	36	46	70	97	100	-
L3	28.5	36.5	51	79	82	-
L4	184.2	242.5	304	408	431.5	-
L5	4	6	10	12	11.5	-
L6	13	20	28	36	42	-
L7	2	3	5	5	6	-
L8	25	32	40	63	70	-
L9	118.2	151.5	176.5	240	241.5	-
C1	60	90	130	180	180	-
C2	70	90	145	200	200	-
C3	4-M4	4-M5	4-M8	4-M12	4-M12	-
C4	14	19	24	35	42	-
C5	50	70	110	114.3	114.3	-
C6	5	8	14	19	15	-
C7	71.9	90.1	126.5	162.5	195.5	-
C8	106.9	137.1	189	237.5	295.5	-
C9	35	43	71	86	119	-
C10	11.5	14.5	27	32	65	-
B1	5	6	10	12	16	-
H1	18	24.5	35	43	59	-

## WAT Series Planetary Gearbox

### FEATURES

- » By using top-level design software for spiral bevel gear, the contact tooth surface load can allow for high torque output through optimal design. The gear is made of high-strength carburized alloy steel and ground to a precision level within DIN 5 standards.
- » The high-precision ground worm and helical gear set, combined with another optimized gear set, can achieve a reduction ratio of 1000:1.
- » The compact design with high torque and low backlash is suitable for precision servo applications.
- » The patented oil seal design eliminates the need for maintenance and oil replacement, thus ensuring long service life.



WATAD/L/R Series



WATAH Series



WATAC Series

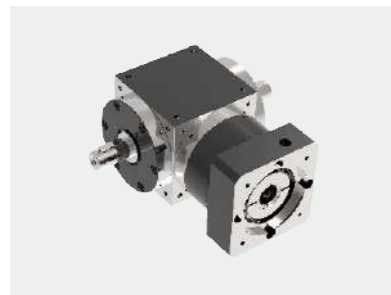

WATD/L/R Series

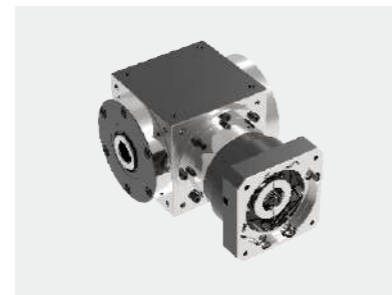

WATH Series



WATC Series

# PLANETARY GEARBOX

## Performance

Specification	Unit	Stage	Ratio	WAT065	WAT090	WAT110	WAT140	WAT170	WAT210			
Rated Output Torque T2N	Nm	1	1	25	78	150	360	580	1300			
			2	25	68	150	360	580	1300			
			4	25	50	150	305	580	1300			
		2	5	25	60	150	330	580	1300			
			6	25	50	140	300	550	1000			
			7	25	50	140	300	550	1000			
			8	25	68	150	360	580	1300			
			10	25	68	150	360	580	1300			
			12	25	68	150	360	580	1300			
			14	25	68	150	360	580	1300			
			16	25	68	150	360	580	1300			
			20	25	68	150	360	580	1300			
			3	25	25	60	150	330	580	1300		
				30	25	50	140	300	550	1000		
				35	25	50	140	300	550	1000		
				40	25	68	150	360	580	1300		
				50	25	68	150	360	580	1300		
		60		25	68	150	360	580	1300			
		70		25	68	150	360	580	1300			
		Emergency stop Torque T2NOT	Nm	1, 2, 3	1~200	2 Times T2N						
Rated Input Speed n <sub>IN</sub>	rpm				1	1~2	3000	3000	3000	3000	3000	2000
					2	4~20	3000	3000	3000	3000	3000	3000
					3	25~200	3000	3000	3000	3000	3000	3000
Max Input Speed n <sub>1B</sub>	rpm				1	1~2	6000	6000	5000	4500	3500	3000
		2	4~20	6000	6000	5000	4500	3500	3000			
		3	25~200	6000	6000	6000	5000	4500	3500			
Super Precision Backlash P0	arcmin	1	1~2	-	-	-	-	-	-			
		2	4~20	≤4	≤4	≤4	≤4	≤4	≤4			
		3	25~200	≤6	≤6	≤6	≤6	≤6	≤6			
Precision Backlash P1	arcmin	1	1~2	≤4	≤4	≤4	≤4	≤4	≤4			
		2	4~20	≤6	≤6	≤6	≤6	≤6	≤6			
		3	25~200	≤8	≤8	≤8	≤8	≤8	≤8			

## SELECTION

## GENERAL NOTICES

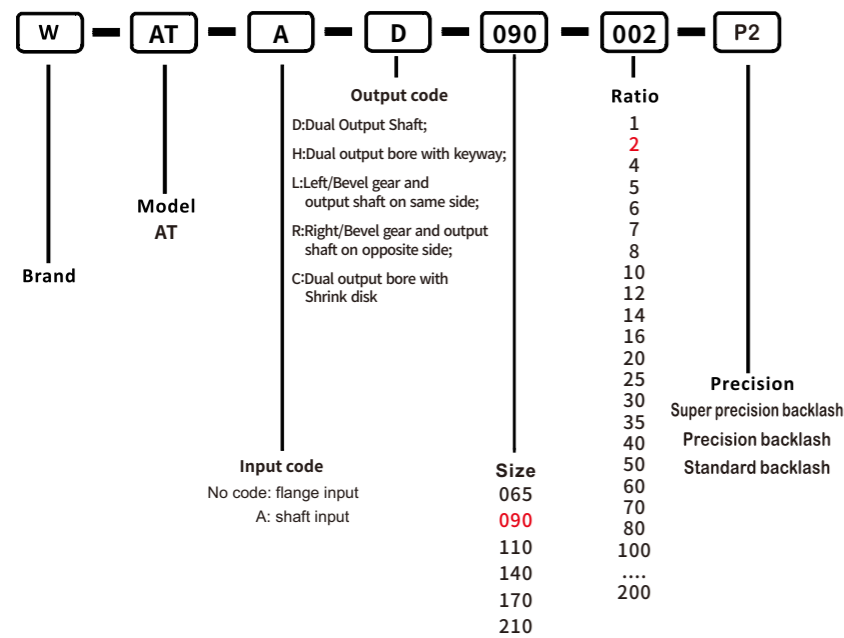

- Type, model and torque
- Ratio or output speed
- Working conditions and connection methods
- Quantity and installed machine name
- Input mode and input speed
- Motor brand model or flange and motor shaft size

# PLANETARY GEARBOX

## Performance

Specification	Unit	Stage	Ratio	WAT065	WAT090	WAT110	WAT140	WAT170	WAT210
Standard Backlash P2	arcmin	1	1~2	≤6	≤6	≤6	≤6	≤6	≤6
		2	4~20	≤8	≤8	≤8	≤8	≤8	≤8
		3	25~200	≤10	≤10	≤10	≤10	≤10	≤10
Allowable Radial Force F2R	N			2000	3200	5000	6500	9100	13000
Allowable Axle Force F2A	N			1000	1600	2500	3250	4550	6500
Service Life	h			20000					
Efficient	%	1	1~2	≥97					
		2	4~20	≥95					
		3	25~200	≥92					
Use of temperature	°C			-20°C~+40°C					
Weight	kg	1	1~2	3	7	11.5	19.5	34	65
		2	4~20	3.2	8	14	24	38	74
		3	25~200	3.4	8.5	14.5	27	39	75
Protection class				Ip65					
Lubrication				Synthetic Lubricating Oil					
Mounting position				In any direction					
Noise level (n1=3000rpm, off load)	dB(A)	1		≤72	≤74	≤76	≤78	≤80	≤82
		2		≤62	≤62	≤64	≤66	≤68	≤72
		3		≤62	≤62	≤64	≤66	≤68	≤72

## WATAD-L1

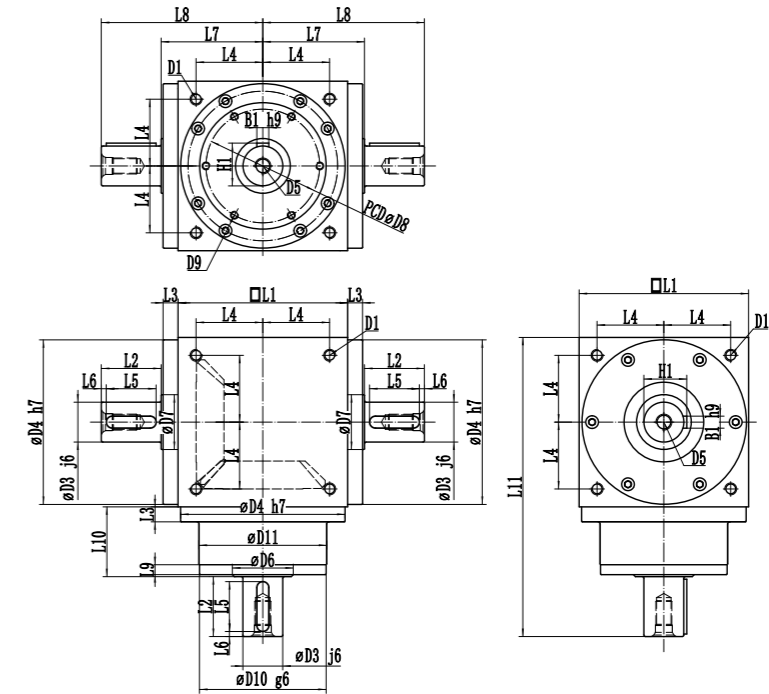

Dimension (single stage, Ratio i=1~2)

Dimension	WATAD065	WATAD090	WATAD110	WATAD140	WATAD170	WATAD210
D1	M5 ↓ 10	M6 ↓ 12	M8 ↓ 16	M10 ↓ 20	M12 ↓ 25	M16 ↓ 32
D3 j6	13	18	22	32	40	50
D4 h7	63	88	108	135	165	205
D5	M4 ↓ 8	M5 ↓ 10	M8 ↓ 16	M12 ↓ 25	M16 ↓ 32	M16 ↓ 32
D6	29.5	39.5	49.5	59.5	74.5	94.5
D7	19.9	29.9	39.9	44.9	54.9	74.9
D8	53	76	95	92	114	142
D9	4-M4 ↓ 8	4-M5 ↓ 10	6-M6 ↓ 12	6-M6 ↓ 12	6-M8 ↓ 16	6-M8 ↓ 16
D10 g6	62.9	87	107	103	127	158
D11	62.5	87.5	106	104	128	160
L1	65	90	110	140	170	210
L2	19.5	35	40	50	60	75
L3	13	15	15	15	15	20
L4	27	36	44	55	67	85
L5	16	25	32	44	55	69
L6	2	5	3	2.5	2.5	2.5
L7	47.5	62	72	87	102	127
L8	67	97	112	137	162	202
L9	8	8	8	10	10	10
L10	43	55	60	60	70	90
L11	127.5	180	210	250	300	375
B1 h9	5	6	6	10	12	14
H1	15	20.5	24.5	35	43	53.5

WATAL-L1

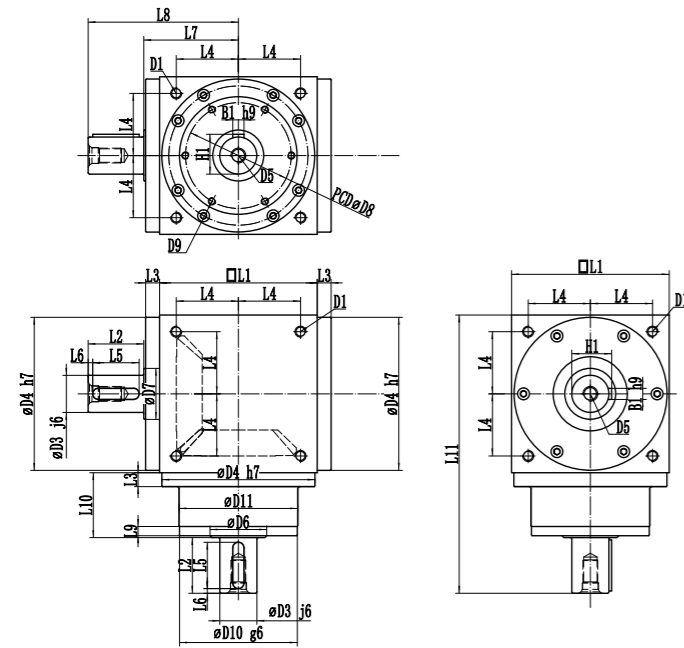

WATAR

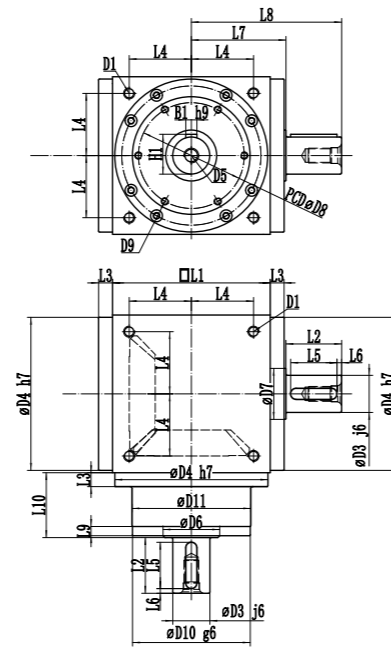

Dimension (single stage, Ratio i=1~2)

Dimension	WATAL/R065	WATAL/R090	WATAL/R110	WATAL/R140	WATAL/R170	WATAL/R210
D1	M5 ↓ 10	M6 ↓ 12	M8 ↓ 16	M10 ↓ 20	M12 ↓ 25	M16 ↓ 32
D3 j6	13	18	22	32	40	50
D4 h7	63	88	108	135	165	205
D5	M4 ↓ 8	M5 ↓ 10	M8 ↓ 16	M12 ↓ 25	M16 ↓ 32	M16 ↓ 32
D6	29.5	39.5	49.5	59.5	74.5	94.5
D7	19.9	29.9	39.9	44.9	54.9	74.9
D8	53	76	95	92	114	142
D9	4-M4 ↓ 8	4-M5 ↓ 10	6-M6 ↓ 12	6-M6 ↓ 12	6-M8 ↓ 16	6-M8 ↓ 16
D10 g6	62.9	87	107	103	127	158
D11	62	86	106	104	128	160
L1	65	90	110	140	170	210
L2	19.5	35	40	50	60	75
L3	13	15	15	15	15	20
L4	27	36	44	55	67	85
L5	16	25	32	44	55	69
L6	2	5	3	2.5	2.5	2.5
L7	47.5	62	72	87	102	127
L8	67	97	112	137	162	202
L9	8	8	8	10	10	10
L10	43	55	60	60	70	90
L11	127.5	180	210	250	300	375
B1 h9	5	6	6	10	12	14
H1	15	20.5	24.5	35	43	53.5

WATAH-L1

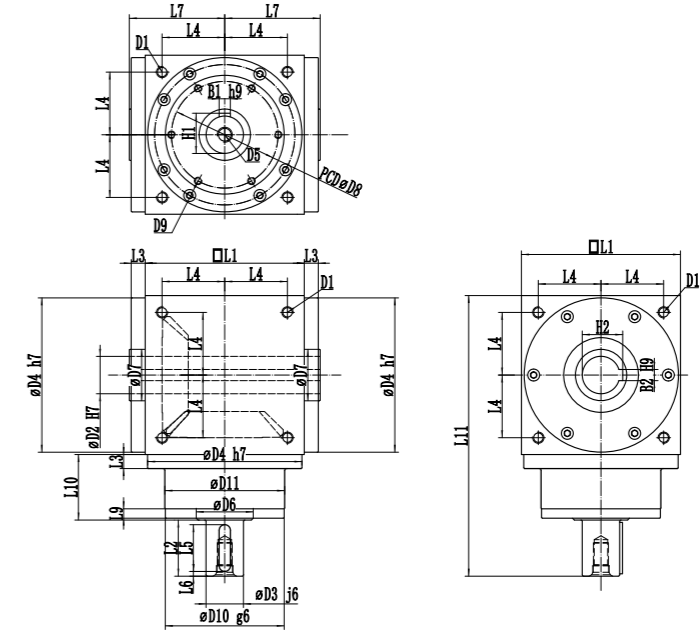

Dimension (single stage, Ratio i=1~2)

Dimension	WATAH065	WATAH090	WATAH110	WATAH140	WATAH170	WATAH210
D1	M5 ↓ 10	M6 ↓ 12	M8 ↓ 16	M10 ↓ 20	M12 ↓ 25	M16 ↓ 32
D2 H7	13	18	22	32	40	50
D3 j6	13	18	22	32	40	50
D4 h7	63	88	108	135	165	205
D5	M4 ↓ 8	M5 ↓ 10	M8 ↓ 16	M12 ↓ 25	M16 ↓ 32	M16 ↓ 32
D6	29.5	39.5	49.5	59.5	74.5	94.5
D7	19.9	29.9	39.9	44.9	54.9	74.9
D8	53	76	95	92	114	142
D9	4-M4 ↓ 8	4-M5 ↓ 10	6-M6 ↓ 12	6-M6 ↓ 12	6-M8 ↓ 16	6-M8 ↓ 16
D10 g6	62.9	87	107	103	127	158
D11	62.5	87.5	106	104	128	160
L1	65	90	110	140	170	210
L2	19.5	35	40	50	60	75
L3	13	15	15	15	15	20
L4	27	36	44	55	67	85
L5	16	25	32	44	55	69
L6	2	5	3	2.5	2.5	2.5
L7	47.5	62	72	87	102	127
L9	8	8	8	10	10	10
L10	43	55	60	60	70	90
L11	127.5	180	210	250	300	375
B1 h9	5	6	6	10	12	14
B2 H9	5	6	6	10	12	14
H1	15	20.5	24.5	35	43	53.5
H2	15.3	20.8	24.8	35.3	43.3	53.8

WATAC-L1

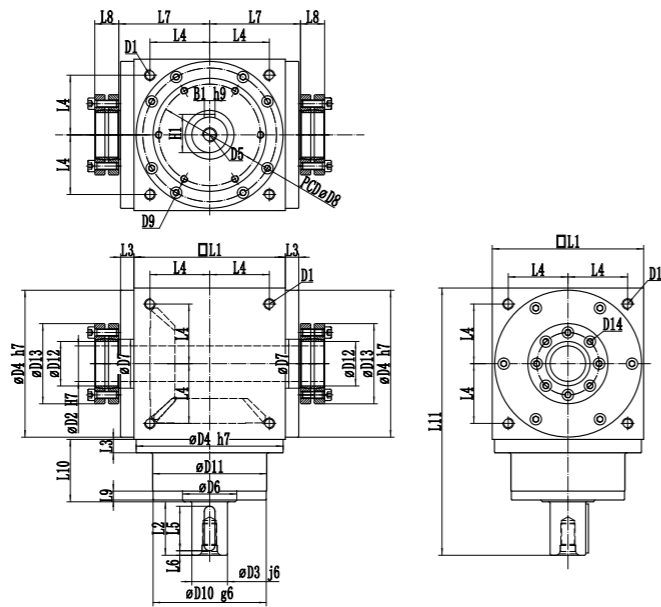

Dimension (single stage, Ratio i=1~2)

Dimension	WATAC065	WATAC090	WATAC110	WATAC140	WATAC170	WATAC210
D1	M5 ↓ 10	M6 ↓ 12	M8 ↓ 16	M10 ↓ 20	M12 ↓ 25	M16 ↓ 32
D2 H7	13	18	22	32	40	50
D3 j6	13	18	22	32	40	50
D4 h7	63	88	108	135	165	205
D5	M4 ↓ 8	M5 ↓ 10	M8 ↓ 16	M12 ↓ 25	M16 ↓ 32	M16 ↓ 32
D6	29.5	39.5	49.5	59.5	74.5	94.5
D7	19.9	29.9	39.9	44.9	54.9	74.9
D8	53	76	95	92	114	142
D9	4-M4 ↓ 8	4-M5 ↓ 10	6-M6 ↓ 12	6-M6 ↓ 12	6-M8 ↓ 16	6-M8 ↓ 16
D10 g6	62.9	87	107	103	127	158
D11	62	86	106	104	128	160
D12	16	22	27	44	50	62
D13	41	50	53	80	90	110
D14	6-M6	6-M6	7-M6	8-M6	8-M8	8-M8
L1	65	90	110	140	170	210
L2	19.5	35	40	50	60	75
L3	13	15	15	15	15	20
L4	27	36	44	55	67	85
L5	16	25	32	44	55	69
L6	2	5	3	2.5	2.5	2.5
L7	47.5	62	72	87	102	127
L8	18	20	20	25	27	30
L9	8	8	8	10	10	10
L10	43	55	60	60	70	90
L11	127.5	180	210	250	300	375
B1 h9	5	6	6	10	12	14
H1	15	20.5	24.5	35	43	53.5

WATL-L2

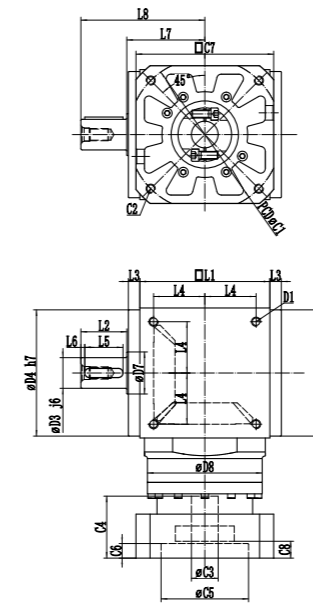

WATR-L2

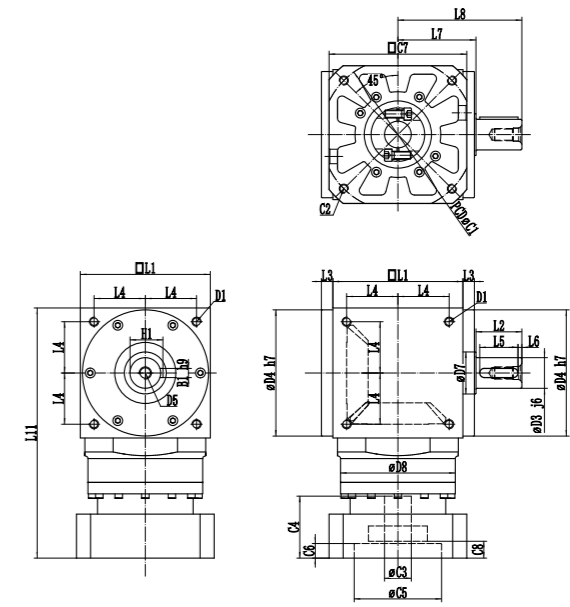

Dimension (double stage, Ratio i=4~20)

Dimension	WATL/R065	WATL/R090	WATL/R110	WATL/R140	WATL/R170	WATL/R210
D1	M5 ↓ 10	M6 ↓ 12	M8 ↓ 16	M10 ↓ 20	M12 ↓ 25	M16 ↓ 32
D3 j6	13	18	22	32	40	50
D4 h7	63	88	108	135	165	205
D5	M4 ↓ 8	M5 ↓ 10	M8 ↓ 16	M12 ↓ 25	M16 ↓ 32	M16 ↓ 32
D7	19.9	29.9	39.9	44.9	54.9	74.9
D8	64	64	94	125	150	170
L1	65	90	110	140	170	210
L2	19.5	35	40	50	60	75
L3	13	15	15	15	15	20
L4	27	36	44	55	67	85
L5	16	25	32	44	55	69
L6	2	5	3	2.5	2.5	2.5
L7	47.5	62	72	87	102	127
L8	67	97	112	137	162	202
L11	129/142	155.8/168.8	197/215	255.5/277.5	327/360	405.3/408.3
B1 h9	5	6	6	10	12	14
H1	15	20.5	24.5	35	43	53.5
C1	70/90	70/90	90/145	145/200	200	200/235
C2	M4/M5	M4/M5	M5/M8	M8/M12	M12	M12
C3	≤14/≤19	≤14/≤19	≤19/≤24	≤24/≤35	≤35/≤42	≤42/≤55
C4	31.5/41	31.5/41	41/59	60/81	81/114	114/117
C5	50/70	50/70	70/110	110/114.3	114.3	114.3/200
C6	5/6	5/6	6/14	14/23	19/15	24
C7	60/80	60/80	80/130	130/180	180	180/220
C8	6/9	6/9	9.5/21.5	19.5/25	22/55	30/33



WATL-L3

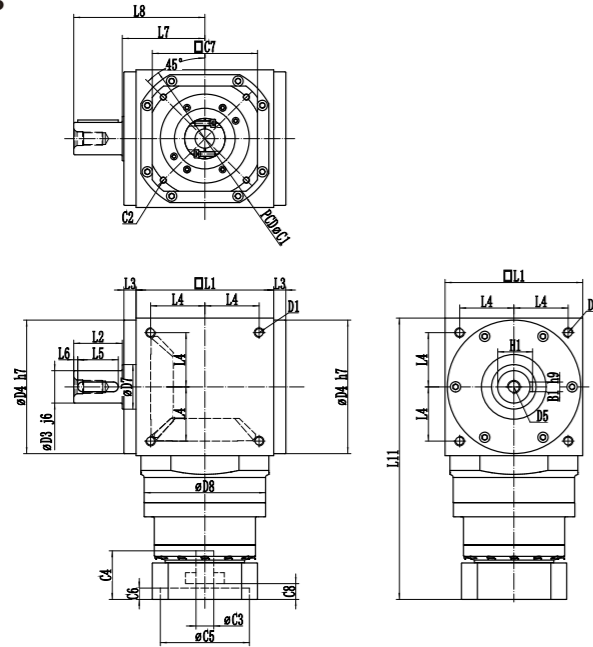

WATR-L3

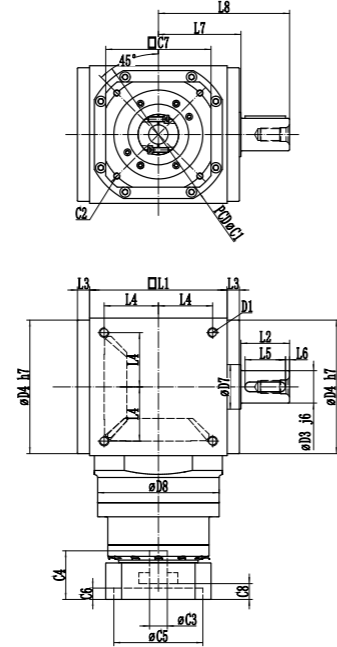

Dimension (3 stage, Ratio i=25~200)

Dimension	WATL/R065	WATL/R090	WATL/R110	WATL/R140	WATL/R170	WATL/R210
D1	M5 ↓ 10	M6 ↓ 12	M8 ↓ 16	M10 ↓ 20	M12 ↓ 25	M16 ↓ 32
D3 j6	13	18	22	32	40	50
D4 h7	63	88	108	135	165	205
D5	M4 ↓ 8	M5 ↓ 10	M8 ↓ 16	M12 ↓ 25	M16 ↓ 32	M16 ↓ 32
D7	19.9	29.9	39.9	44.9	54.9	74.9
D8	64	64	94	125	150	170
L1	65	90	110	140	170	210
L2	19.5	35	40	50	60	75
L3	13	15	15	15	15	20
L4	27	36	44	55	67	85
L5	16	25	32	44	55	69
L6	2	5	3	2.5	2.5	2.5
L7	47.5	62	72	87	102	127
L8	67	97	112	137	162	202
L11	161/174	187.8/200.8	216.5/234.5	270/300.5	347.5/388	438/471
B1 h9	5	6	6	10	12	14
H1	15	20.5	24.5	35	43	53.5
C1	70/90	70/90	70/90	90/145	145/200	200
C2	M4/M5	M4/M5	M4/M5	M5/M8	M8/M12	M12
C3	≤14/≤19	≤14/≤19	≤14/≤19	≤19/≤24	≤24/≤35	≤35/≤42
C4	31.5/41	31.5/41	31.5/41	41/60	60/81	81/114
C5	50/70	50/70	50/70	70/110	110/114.3	114.3
C6	5/6	5/6	50/70	6/14	14/19	19/15
C7	60/80	60/80	60/80	80/130	130/180	180
C8	6/9	6/9	6/9.5	9.5/19.5	19.5/22	22/55

WATD-L2

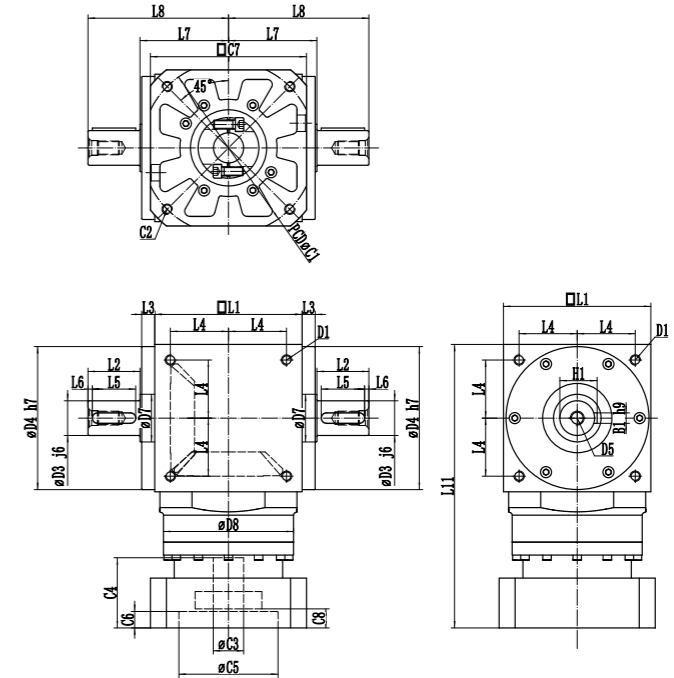

Dimension (double stage, Ratio i=4~20)

Dimension	WATD065	WATD090	WATD110	WATD140	WATAD170	WATAD210
D1	M5 ↓ 10	M6 ↓ 12	M8 ↓ 16	M10 ↓ 20	M12 ↓ 25	M16 ↓ 32
D3 j6	13	18	22	32	40	50
D4 h7	63	88	108	135	165	205
D5	M4 ↓ 8	M5 ↓ 10	M8 ↓ 16	M12 ↓ 25	M16 ↓ 32	M16 ↓ 32
D7	19.9	29.9	39.9	44.9	54.9	74.9
D8	64	64	94	125	150	170
L1	65	90	110	140	170	210
L2	19.5	35	40	50	60	75
L3	13	15	15	15	15	20
L4	27	36	44	55	67	85
L5	16	25	32	44	55	69
L6	2	5	3	2.5	2.5	2.5
L7	47.5	62	72	87	102	127
L8	67	97	112	137	162	202
L11	129/142	155.8/168.8	197/215	255.5/277.5	327/360	405.3/408.3
B1 h9	5	6	6	10	12	14
H1	15	20.5	24.5	35	43	53.5
C1	70/90	70/90	90/145	145/200	200	200/235
C2	M4/M5	M4/M5	M5/M8	M8/M12	M12	M12
C3	≤14/≤19	≤14/≤19	≤19/≤24	≤24/≤35	≤35/≤42	≤42/≤55
C4	31.5/41	31.5/41	41/59	60/81	81/114	114/117
C5	50/70	50/70	70/110	110/114.3	114.3	114.3/200
C6	5/6	5/6	6/14	14/23	19/15	24
C7	60/80	60/80	80/130	130/180	180	180/220
C8	6/9	6/9	9.5/21.5	19.5/25	22/55	30/33

WATD-L3

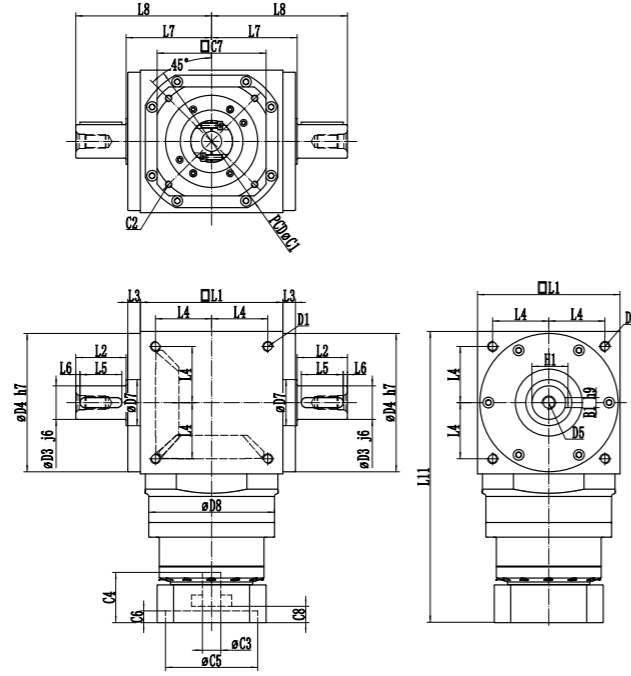

Dimension (3 stage, Ratio i=25~200)

Dimension	WATD065	WATD090	WATD110	WATD140	WATAD170	WATAD210
D1	M5 ↓ 10	M6 ↓ 12	M8 ↓ 16	M10 ↓ 20	M12 ↓ 25	M16 ↓ 32
D3 j6	13	18	22	32	40	50
D4 h7	63	88	108	135	165	205
D5	M4 ↓ 8	M5 ↓ 10	M8 ↓ 16	M12 ↓ 25	M16 ↓ 32	M16 ↓ 32
D7	19.9	29.9	39.9	44.9	54.9	74.9
D8	64	64	94	125	150	170
L1	65	90	110	140	170	210
L2	19.5	35	40	50	60	75
L3	13	15	15	15	15	20
L4	27	36	44	55	67	85
L5	16	25	32	44	55	69
L6	2	5	3	2.5	2.5	2.5
L7	47.5	62	72	87	102	127
L8	67	97	112	137	162	202
L11	161/174	187.8/200.8	216.5/234.5	270/300.5	347.5/388	438/471
B1 h9	5	6	6	10	12	14
H1	15	20.5	24.5	35	43	53.5
C1	70/90	70/90	90/145	145/200	200	200/235
C2	M4/M5	M4/M5	M4/M5	M5/M8	M8/M12	M12
C3	≤14/≤19	≤14/≤19	≤19/≤24	≤19/≤24	≤24/≤35	≤35/≤42
C4	31.5/41	31.5/41	31.5/41	41/60	60/81	81/114
C5	50/70	50/70	50/70	70/110	110/114.3	114.3
C6	5/6	5/6	5/6	6/14	14/19	19/15
C7	60/80	60/80	60/80	80/130	130/180	180
C8	6/9	6/9	6/9.5	9.5/19.5	19.5/22	22/55

WATH-L2

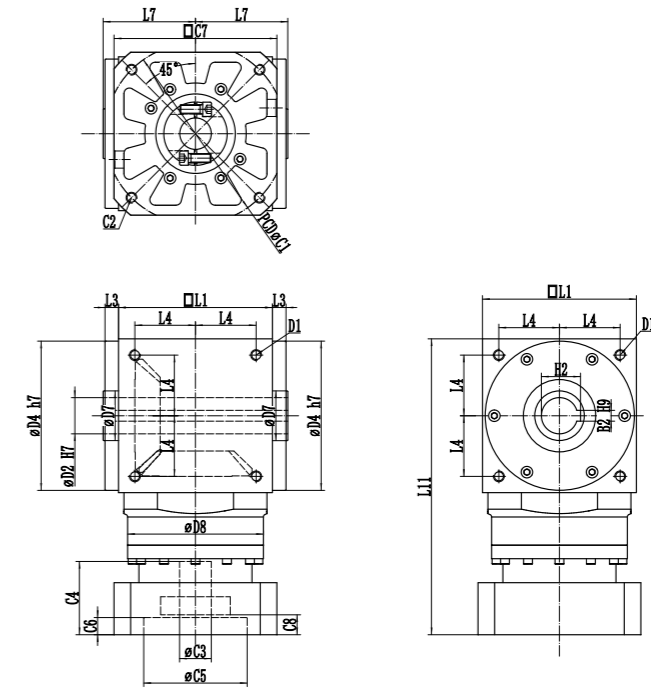

Dimension (double stage, Ratio i=4~20)

Dimension	WATH065	WATH090	WATH110	WATH140	WATH170	WATH210
D1	M5 ↓ 10	M6 ↓ 12	M8 ↓ 16	M10 ↓ 20	M12 ↓ 25	M16 ↓ 32
D2 H7	13	18	22	32	40	50
D4 h7	63	88	108	135	165	205
D7	19.9	29.9	39.9	44.9	54.9	74.9
D8	64	64	94	125	150	170
L1	65	90	110	140	170	210
L3	13	15	15	15	15	20
L4	27	36	44	55	67	85
L7	47.5	62	72	87	102	127
L11	129/142	155.8/168.8	197/215	255.5/277.5	327/36	405.3/408.3
B2 H9	5	6	6	10	012	14
H2	15.3	20.8	24.8	35.3	43.3	53.8
C1	70/90	70/90	90/145	145/200	200	200/235
C2	M4/M5	M4/M5	M5/M8	M8/M12	M12	M12
C3	≤14/≤19	≤14/≤19	≤19/≤24	≤24/≤35	≤35/≤42	≤42/≤55
C4	31.5/41	31.5/41	41/59	60/81	81/114	114/117
C5	50/70	50/70	70/110	110/114.3	114.3	114.3/200
C6	5/6	5/6	6/14	14/23	19/15	24
C7	60/80	60/80	80/130	130/180	180	180/220
C8	6/9	6/9	9.5/21.5	19.5/25	22/55	30/33

WATH-L3

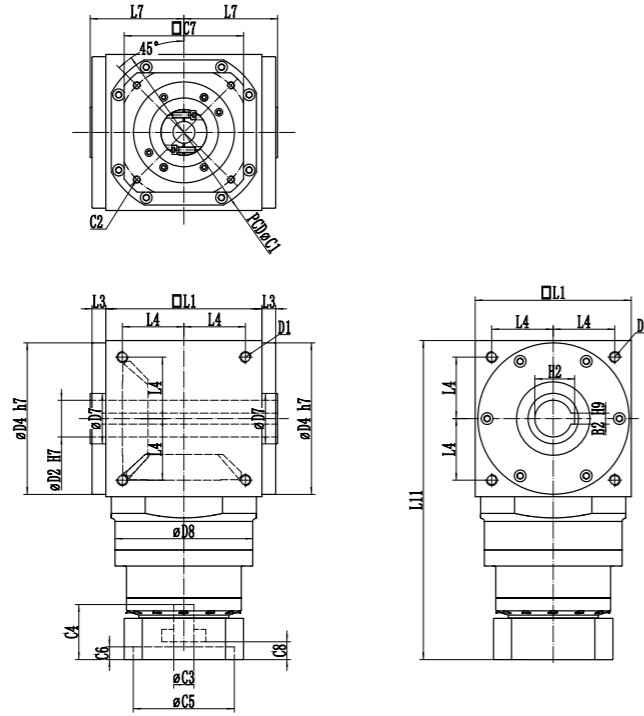

Dimension (double stage, Ratio i=25~200)

Dimension	WATH065	WATH090	WATH110	WATH140	WATH170	WATH210
D1	M5 ↓ 10	M6 ↓ 12	M8 ↓ 16	M10 ↓ 20	M12 ↓ 25	M16 ↓ 32
D2 H7	13	18	22	32	40	50
D4 h7	63	88	108	135	165	205
D7	19.9	29.9	39.9	44.9	54.9	74.9
D8	64	64	94	125	150	170
L1	65	90	110	140	170	210
L3	13	15	15	15	15	20
L4	27	36	44	55	67	85
L7	47.5	62	72	87	102	127
L11	161/174	187.8/200.8	216.5/234.5	270/300.5	347.5/388	438/471
B2 H9	5	6	6	10	12	14
H2	15.3	20.8	24.8	35.3	43.3	53.8
C1	70/90	70/90	70/90	90/145	145/200	200
C2	M4/M5	M4/M5	M4/M5	M5/M8	M8/M12	M12
C3	≤14/≤19	≤14/≤19	≤14/≤19	≤19/≤24	≤24/≤35	≤35/≤42
C4	31.5/41	31.5/41	31.5/41	41/60	60/81	81/114
C5	50/70	50/70	50/70	70/110	110/114.3	114.3
C6	5/6	5/6	5/6	6/14	14/19	19/15
C7	60/80	60/80	60/80	80/130	130/180	180
C8	6/9	6/9	6/9.5	9.5/19.5	19.5/22	22/55

WATC-L2

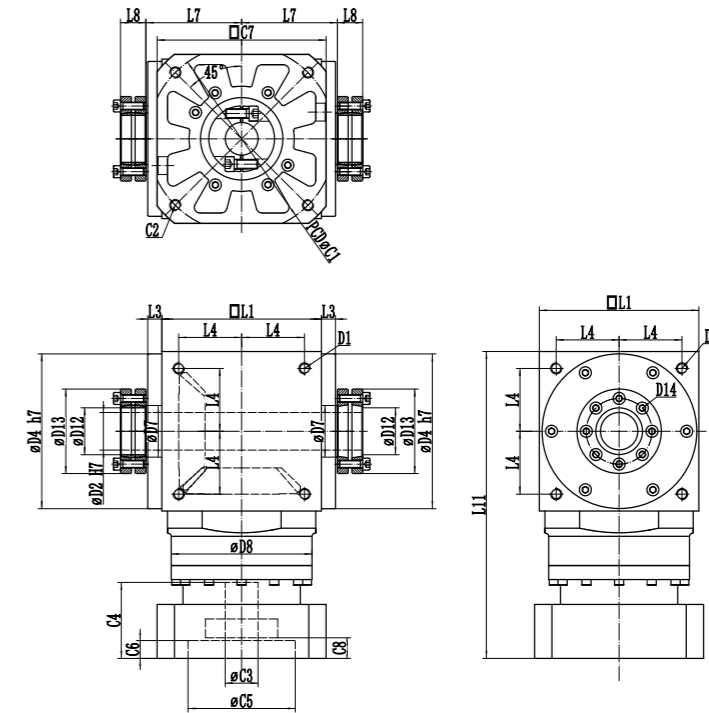

Dimension (double stage, Ratio i=4~20)

Dimension	WATC065	WATC090	WATC110	WATC140	WATC170	WATC210
D1	M5 ↓ 10	M6 ↓ 12	M8 ↓ 16	M10 ↓ 20	M12 ↓ 25	M16 ↓ 32
D2 H7	13	18	22	32	40	50
D4 h7	63	88	108	135	165	205
D7	19.9	29.9	39.9	44.9	54.9	74.9
D8	64	64	94	125	150	170
D12	16	22	27	44	50	62
D13	41	50	53	80	90	110
D14	6-M6	6-M6	7-M6	8-M6	8-M8	8-M8
L1	65	90	110	140	170	210
L3	13	15	15	15	15	20
L4	27	36	44	55	67	85
L7	47.5	62	72	87	102	127
L8	18	20	20	25	27	30
L11	129/142	155.8/168.8	197/215	255.5/277.5	327/360	405.3/408.3
C1	70/90	70/90	90/145	145/200	200	200/235
C2	M4/M5	M4/M5	M5/M8	M8/M12	M12	M12
C3	≤14/≤19	≤14/≤19	≤19/≤24	≤24/≤35	≤35/≤42	≤42/≤55
C4	31.5/41	31.5/41	41/59	60/81	81/114	114/117
C5	50/70	50/70	70/110	110/114.3	114.3	114.3/200
C6	5/6	5/6	6/14	14/23	19/15	24
C7	60/80	60/80	80/130	130/180	180	180/220
C8	6/9	6/9	9.5/21.5	19.5/25	22/55	30/33

WATC-L3

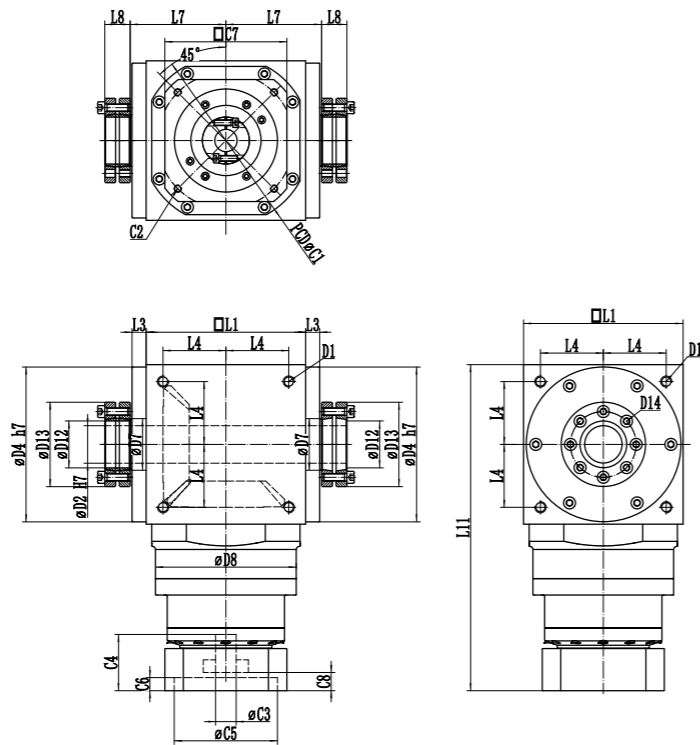

Dimension (3 stage, Ratio i=25~200)

Dimension	WATC065	WATC090	WATC110	WATC140	WATC170	WATC210
D1	M5 ↓ 10	M6 ↓ 12	M8 ↓ 16	M10 ↓ 20	M12 ↓ 25	M16 ↓ 32
D2 H7	13	18	22	32	40	50
D4 h7	63	88	108	135	165	205
D7	19.9	29.9	39.9	44.9	54.9	74.9
D8	64	64	94	125	150	170
D12	16	22	27	44	50	62
D13	41	50	53	80	90	110
D14	6-M6	6-M6	7-M6	8-M6	8-M8	8-M8
L1	65	90	110	140	170	210
L3	13	15	15	15	15	20
L4	27	36	44	55	67	85
L7	47.5	62	72	87	102	127
L8	18	20	20	25	27	30
L11	161/174	187.8/200.8	216.5/234.5	270/300.5	347.5/388	438/471
C1	70/90	70/90	70/90	90/145	145/200	200
C2	M4/M5	M4/M5	M4/M5	M5/M8	M8/M12	M12
C3	≤14/≤19	≤14/≤19	≤14/≤19	≤19/≤24	≤24/≤35	≤35/≤42
C4	31.5/41	31.5/41	31.5/41	41/60	60/81	81/114
C5	50/70	50/70	50/70	70/110	110/114.3	114.3
C6	5/6	5/6	5/6	6/14	14/19	19/15
C7	60/80	60/80	60/80	80/130	130/180	180
C8	6/9	6/9	6/9.5	9.5/19.5	19.5/22	22/55

Rotation Direction Diagram

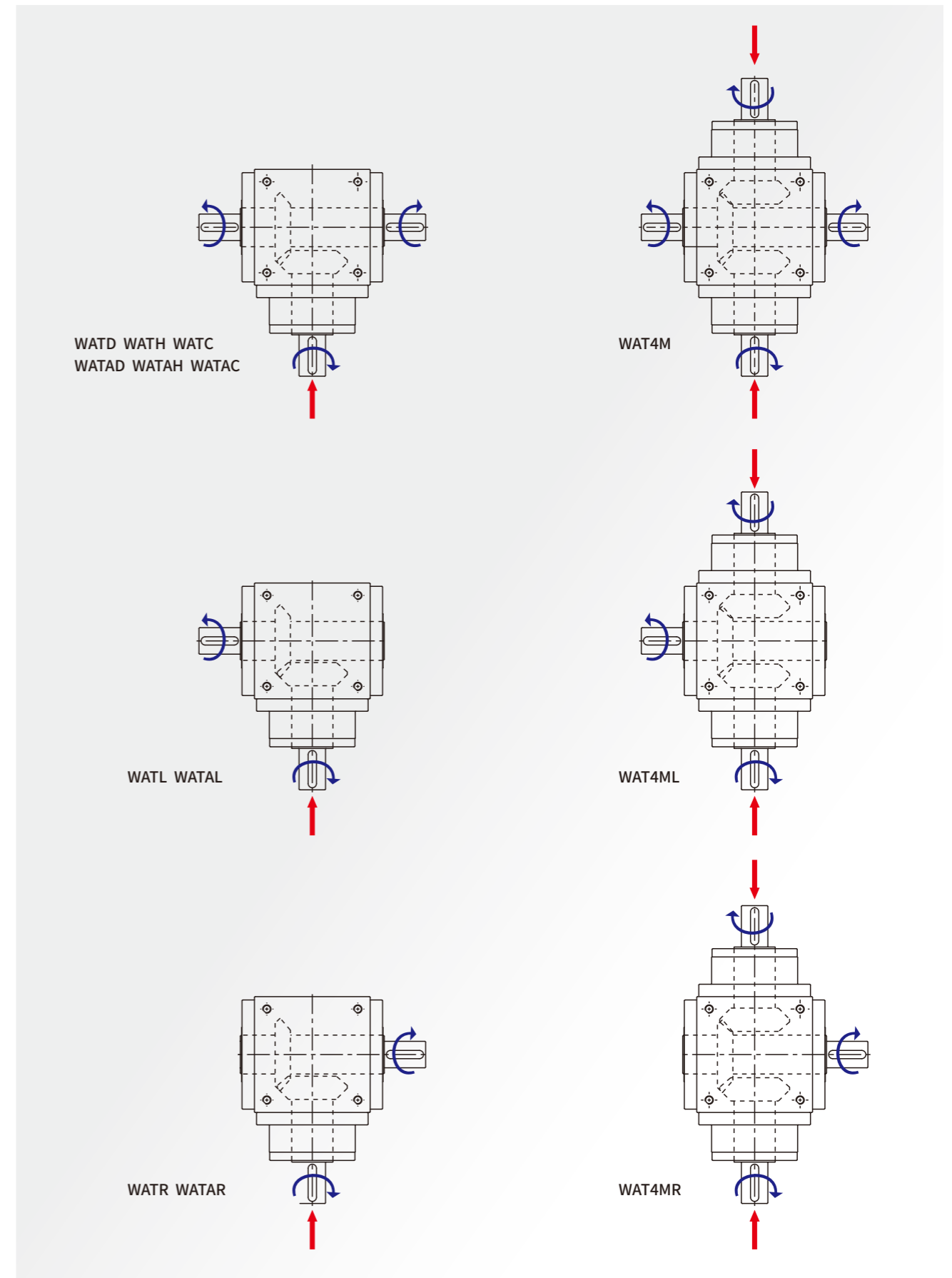

# WTN Hollow Rotary Platform

## FEATURES

- » Competitive price
- » Larger hollow hole, convenient for wiring and piping
- » Compact size, greater power density
- » Crossed roller bearing output, with greater load-bearing capacity

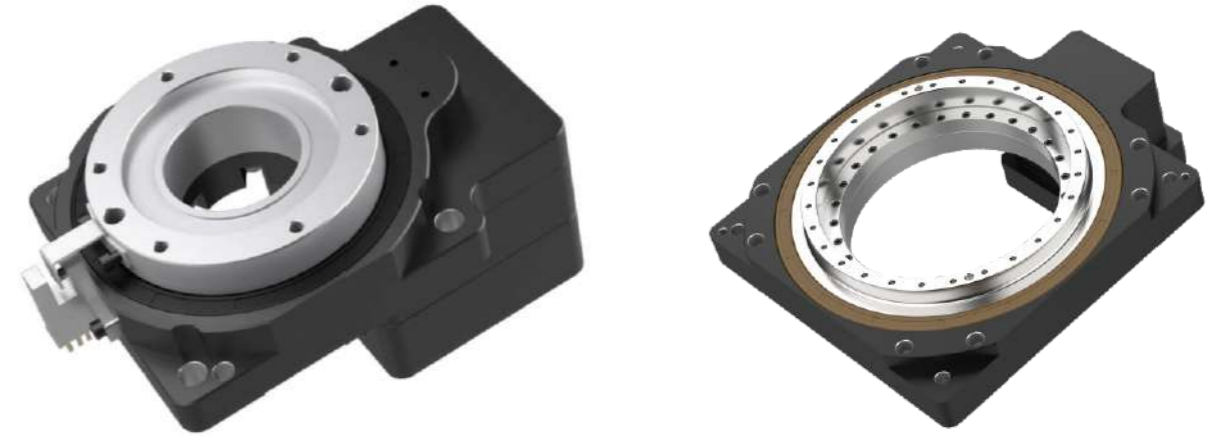

## SELECTION

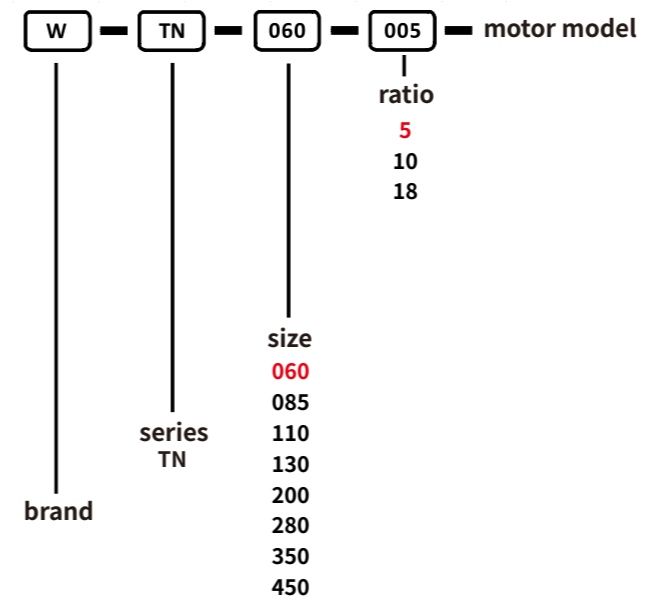

## GENERAL NOTICES

- Type, model and torque
- Ratio or output speed
- Working conditions and connection methods
- Quantity and installed machine name
- Input mode and input speed
- Motor brand model or flange and motor shaft size



### WTN060 Heavy-load type

#### Performance

Specifications	Unit	WTN060	WTN060+WVRB042	WTN060+WRS042
Applicable motor models		42 stepper motor	50W~100W servo motor	motor shaft diameter ≤ 8mm
Bearing type		crossed roller bearing		
Ratio		5 10 18	25 40 50 70 100	15 30 50
Rotational inertia	Kg.m <sup>2</sup>	3507x10 <sup>-7</sup>		
Rated output torque	N·m	5.2 4.6 1.2	5.2	5.2
Rated output speed	rpm	300		
Angular transmission accuracy	arcmin	<2		
Reset positioning accuracy	arcsec	<15		
Backlash	arcmin	<1	<3	<3
Allowable axial load	N	250		
Allowable moment of inertia	N·m	5		
Parallelism of rotation platform	mm	0.015		
Concentricity of rotation platform	mm	0.01		
Output end face runout	mm	0.008		
Noise	dB	65	60	65
Service life	h	20000		
Protection level	IP	40		
Weight	Kg	0.6	1.2	1.3

#### Ratio 5/10 dimension

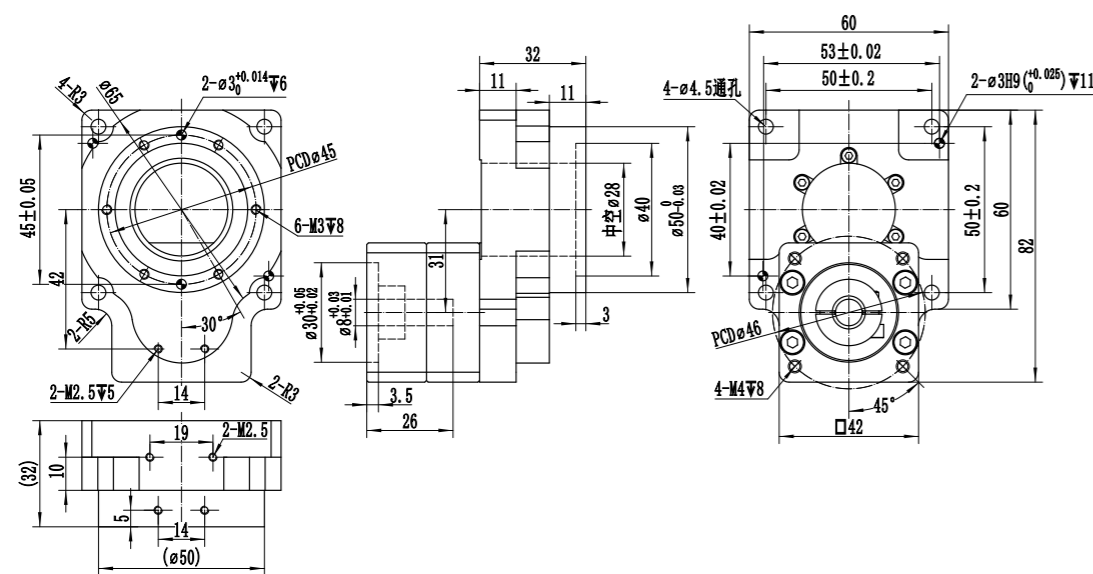

#### Ratio 18 dimension

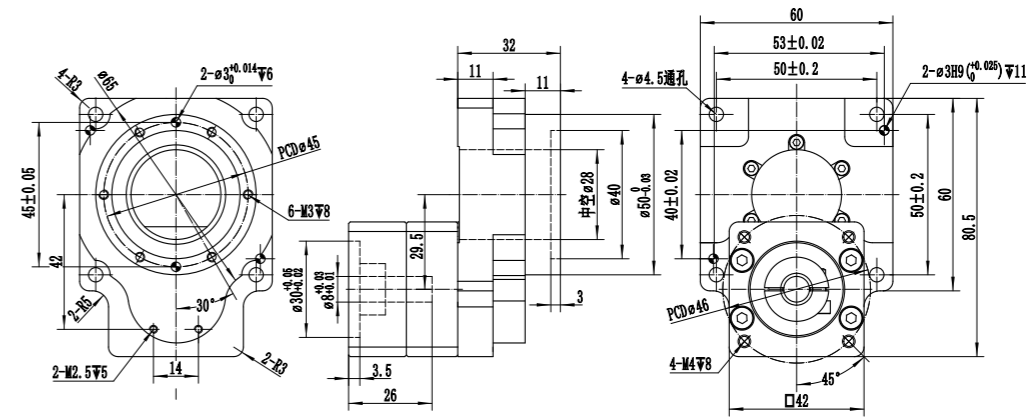

#### Combined gearbox dimension

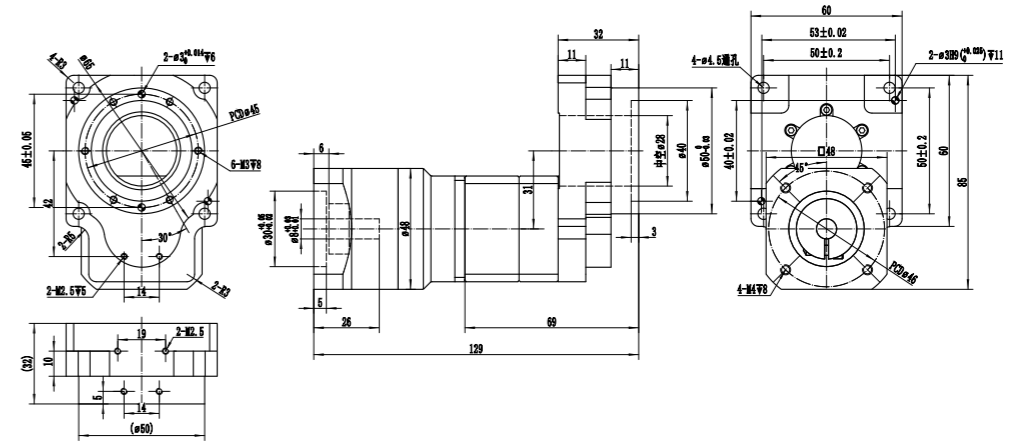

#### Combined right-angle gearbox dimension

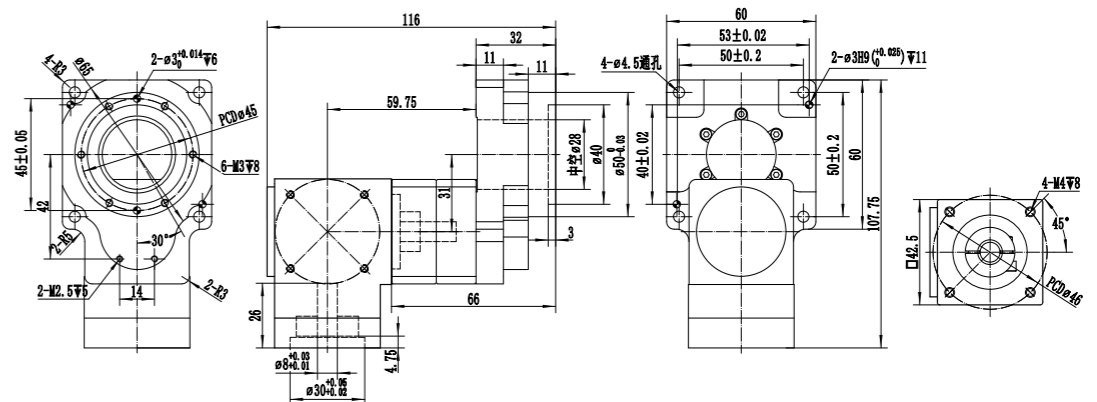

### WTN085 Heavy-load type

#### Performance

Specifications	Unit	WTN085	WTN085+WVRB060	WTN085+WRS060
Applicable motor models		57 stepper motor	200W~400W servo motor	motor shaft diameter≤14mm
Bearing type		crossed roller bearing		
Ratio		5 10	30 40 50 70 100	15 30 50
Rotational inertia	Kg.m <sup>2</sup>	12593x10 <sup>-7</sup>		
Rated output torque	N·m	12 10	12	12
Rated output speed	rpm	300		
Angular transmission accuracy	arcmin	<2		
Reset positioning accuracy	arcsec	<15		
Backlash	arcmin	<1	<2	<2
Allowable axial load	N	500		
Allowable moment of inertia	N·m	10		
Parallelism of rotation platform	mm	0.015		
Concentricity of rotation platform	mm	0.01		
Output end face runout	mm	0.008		
Noise	dB	65	60	65
Service life	h	20000		
Protection level	IP	40		
Weight	Kg	1.2	2.7	2.5

#### Ratio 10 dimension

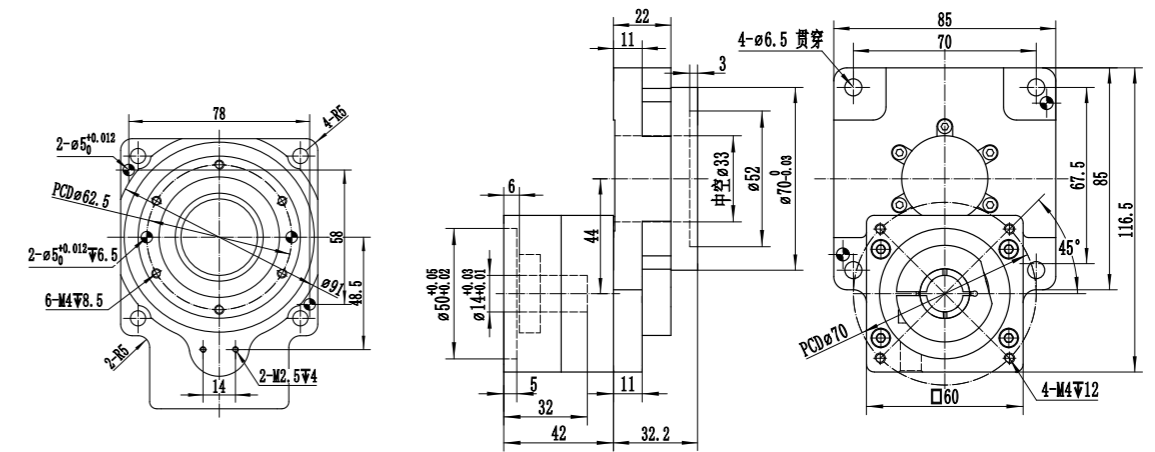

#### Combined gearbox dimension

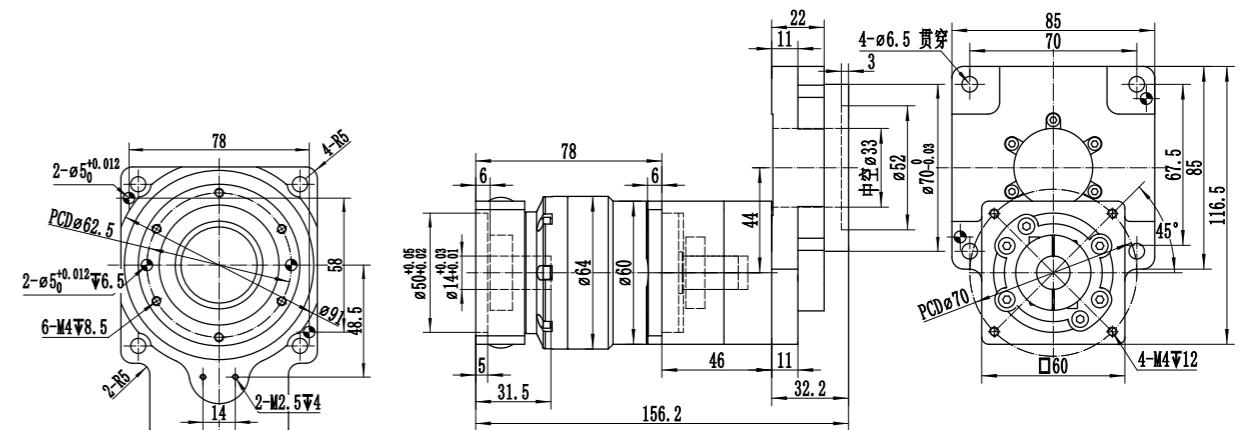

#### Ratio 5 dimension

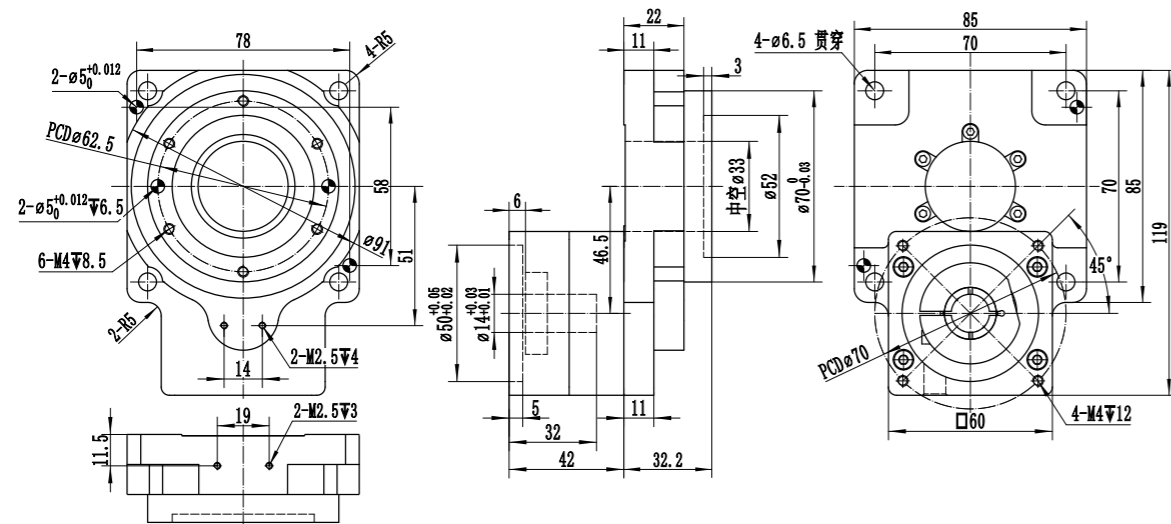

Combined right-angle gearbox dimension

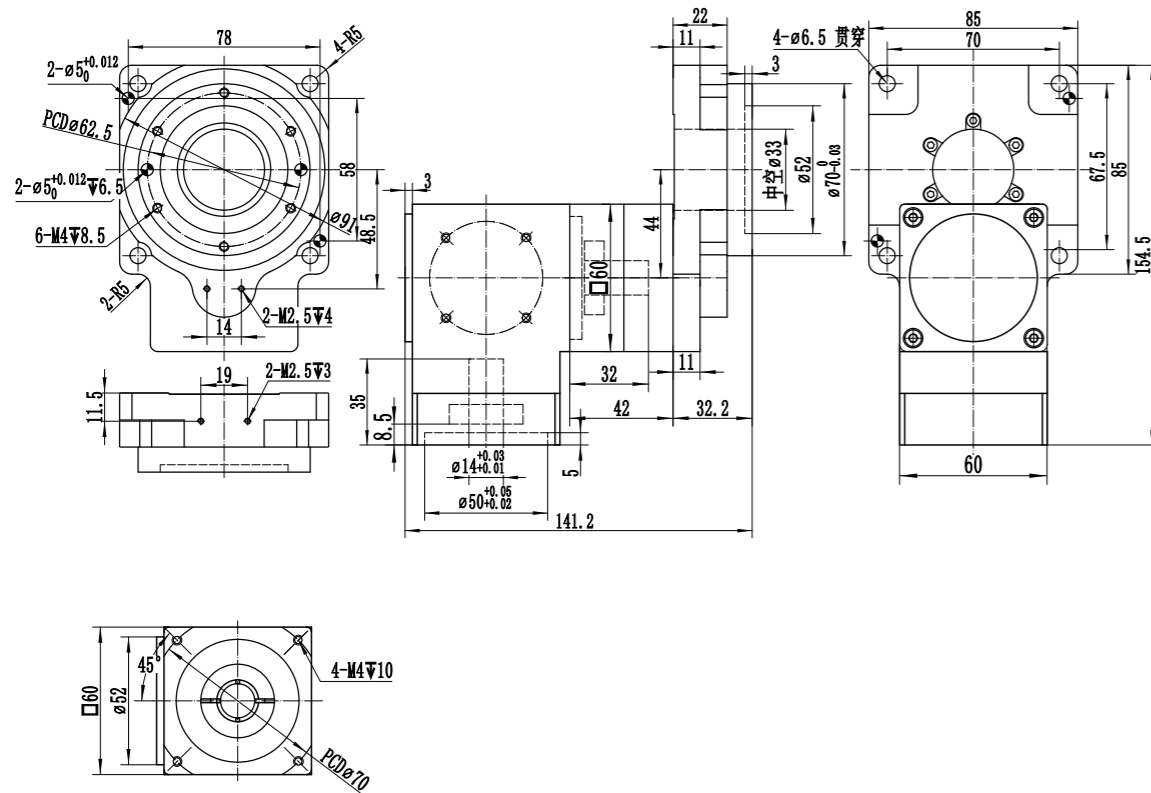

WTN110 Heavy-load type

Performance

Specifications	Unit	WTN110	WTN110+WVRB060	WTN110+WRS060
Applicable motor models		57 stepper motor	200W~400W servo motor	motor shaft diameter $\leq 14$ mm
Bearing type		crossed roller bearing		
Ratio		10	30 40 50 70 100	10 30 50
Rotational inertia	Kg.m <sup>2</sup>	1483x10 <sup>-6</sup>		
Rated output torque	N·m	40	40	40
Rated output speed	rpm	300		
Angular transmission accuracy	arcmin	<1.5		
Reset positioning accuracy	arcsec	<15		
Backlash	arcmin	<1	<2	<2
Allowable axial load	N	1000		
Allowable moment of inertia	N·m	25		
Parallelism of rotation platform	mm	0.02		
Concentricity of rotation platform	mm	0.012		
Output end face runout	mm	0.012		
Noise	dB	65	60	65
Service life	h	20000		
Protection level	IP	40		
Weight	Kg	2.2	3.5	3.5

Ratio 10 dimension

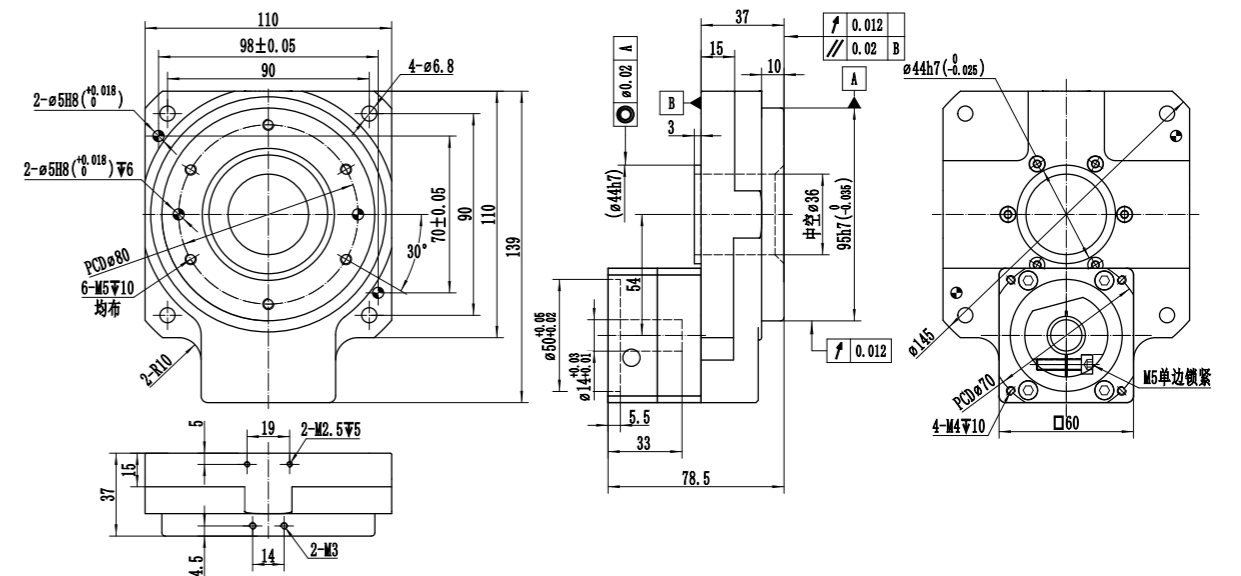

Combined gearbox dimension

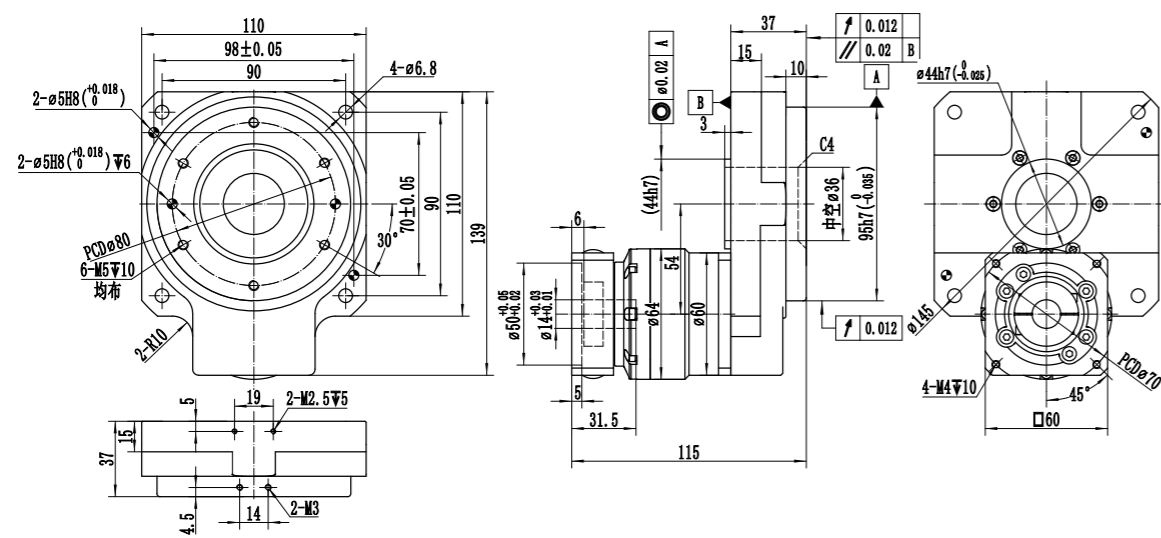

Combined right-angle gearbox dimension

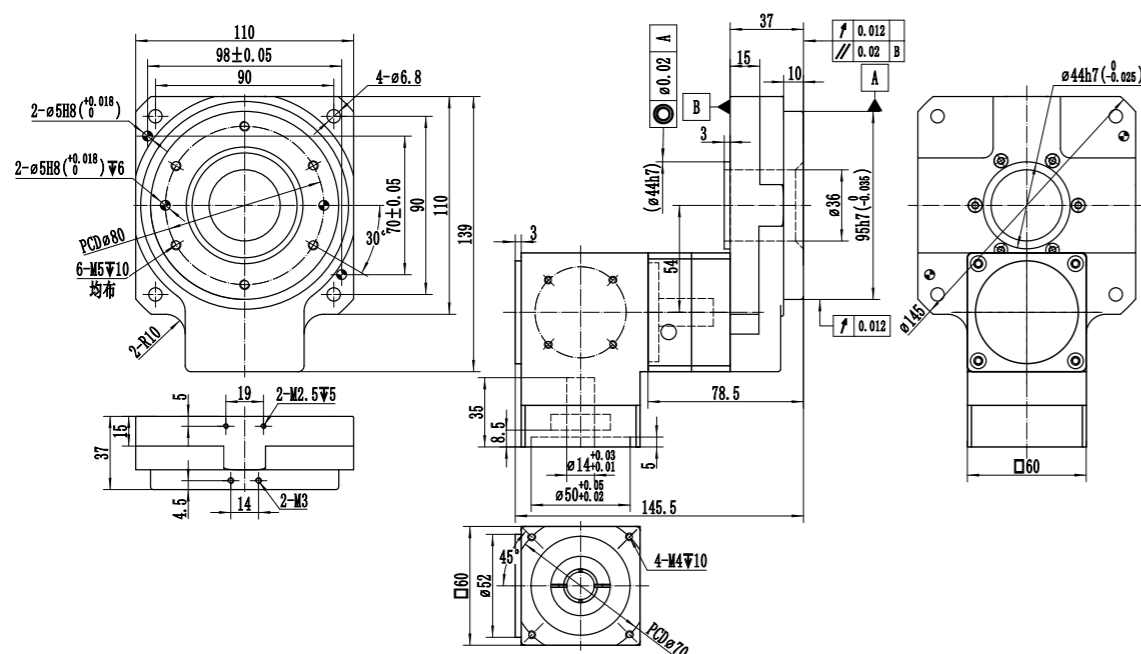

WTN130 Heavy-load type

Performance

Specifications	Unit	WTN130	WTN130+WVRB060	WTN130+WRS060
Applicable motor models		57 stepper motor	200W~400W servo motor	motor shaft diameter ≤ 14mm
Bearing type		crossed roller bearing		
Ratio		10 18	30 40 50 70 100	10 30 50
Rotational inertia	Kg.m <sup>2</sup>	8155x10 <sup>-6</sup>		
Rated output torque	N·m	32 20	32	32
Rated output speed	rpm	200		
Angular transmission accuracy	arcmin	<1.5		
Reset positioning accuracy	arcsec	<15		
Backlash	arcmin	<1	<2	<2
Allowable axial load	N	2000		
Allowable moment of inertia	N·m	50		
Parallelism of rotation platform	mm	0.02		
Concentricity of rotation platform	mm	0.012		
Output end face runout	mm	0.012		
Noise	dB	65	60	65
Service life	h	20000		
Protection level	IP	40		
Weight	Kg	2.8	4.3	4.1

Ratio 10/18 dimension

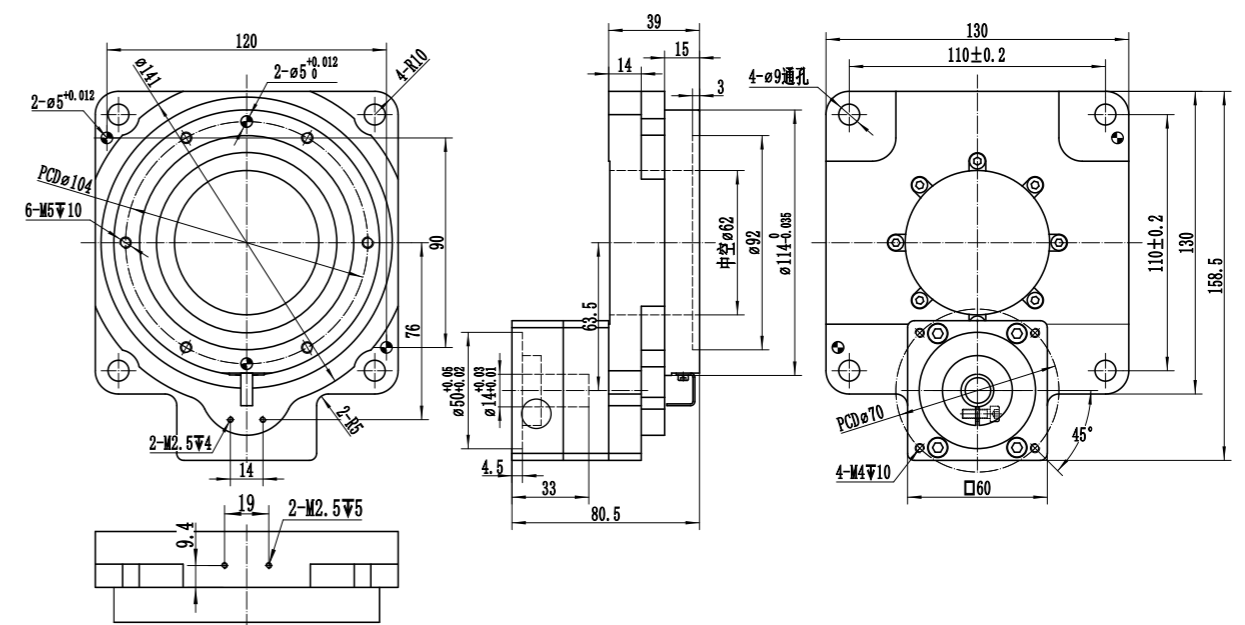





Combined gearbox dimension

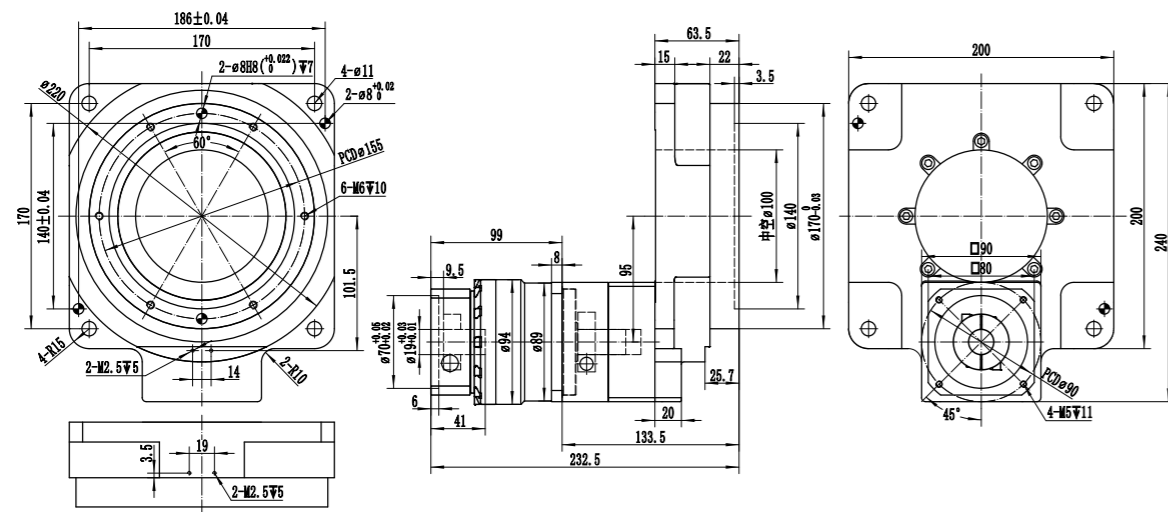

Combined right-angle gearbox dimension

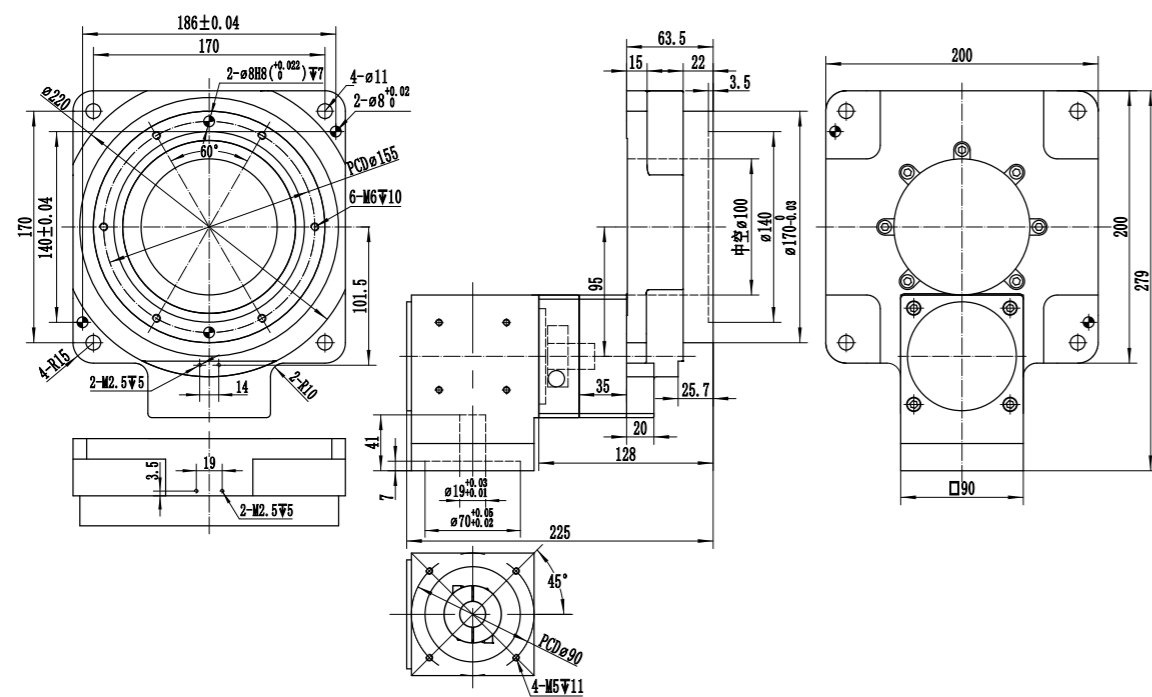

WTN280 Heavy-load type

Performance

Specifications	Unit	WTN280	WTN280+WVRB115
Applicable motor models		110/130 stepper motor	1000W~3000W servo motor motor shaft diameter $\leq 24$ mm
Bearing type			crossed roller bearing
Ratio		10	30 40 50 70 100
Rotational inertia	Kg.m <sup>2</sup>		14600x10-5
Rated output torque	N·m	180	180
Emergency stop Torque T2NOT	rpm		Rated output torque
Rated output speed	rpm		200
Angular transmission accuracy	arcmin		<1
Reset positioning accuracy	arcsec		<10
Backlash	arcmin	<1	<2
Allowable axial load	N		7000
Allowable moment of inertia	N·m		200
Parallelism of rotation platform	mm		0.030
Concentricity of rotation platform	mm		0.015
Output end face runout	mm		0.015
Noise	dB	71	65
Service life	h		20000
Protection level	IP		40
Weight	Kg	18	25.8

Ratio 10 dimension

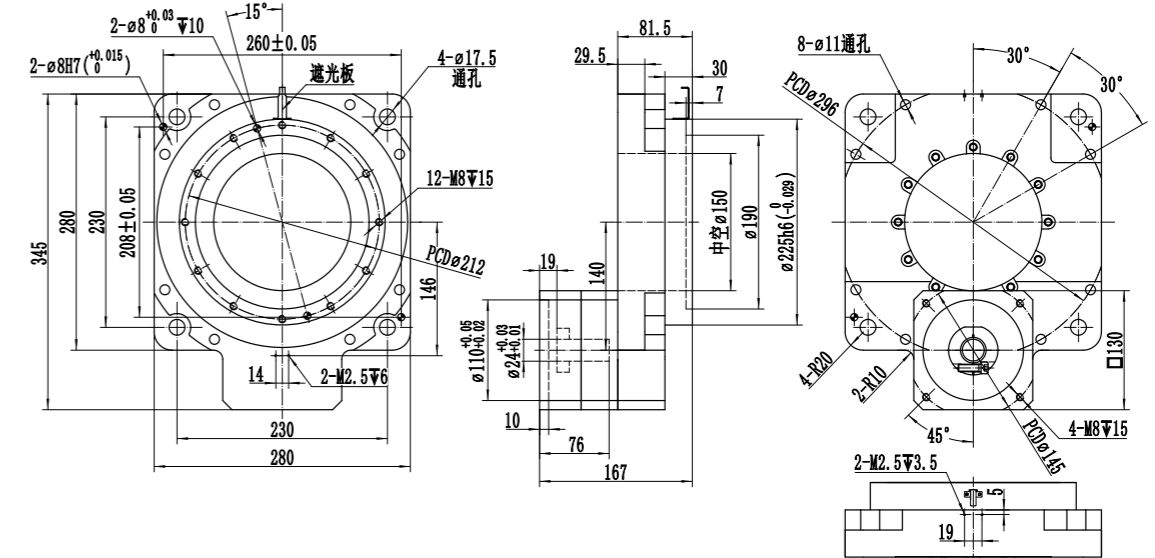

Combined gearbox dimension

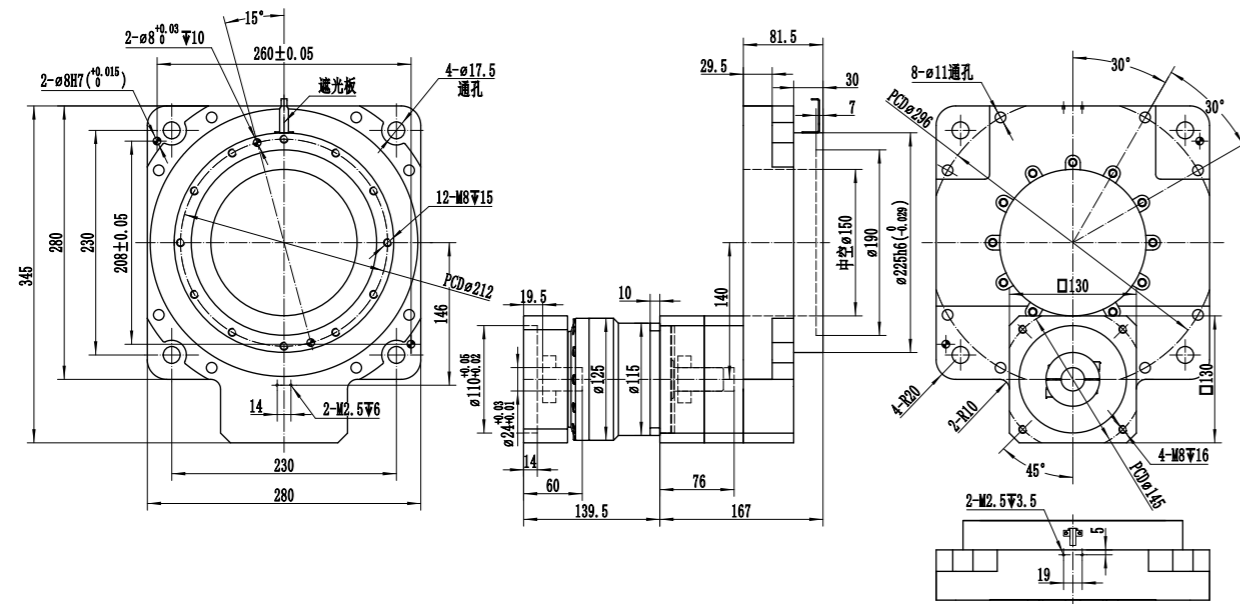

WTN350 Heavy-load type

Performance

Specifications	Unit	WTN350	WTN350+WVRB115
Applicable motor models		130 stepper motor	1000W~3000W servo motor motor shaft diameter ≤35mm
Bearing type			crossed roller bearing
Ratio		10 18	30 40 50 70 100
Rotational inertia	Kg.m <sup>2</sup>		25500X10-5
Rated output torque	N·m	320 260	320
Emergency stop Torque T2NOT	rpm		Rated output torque
Rated output speed	rpm		150
Angular transmission accuracy	arcmin		<1
Reset positioning accuracy	arcsec		<10
Backlash	arcmin	<1	<1.5
Allowable axial load	N		9000
Allowable moment of inertia	N·m		300
Parallelism of rotation platform	mm		0.03
Concentricity of rotation platform	mm		0.015
Output end face runout	mm		0.015
Noise	dB	73	66
Service life	h		20000
Protection level	IP		40
Weight	Kg	25.5	33.3

Ratio 10/18 dimension(motor shaft OD 24mm)

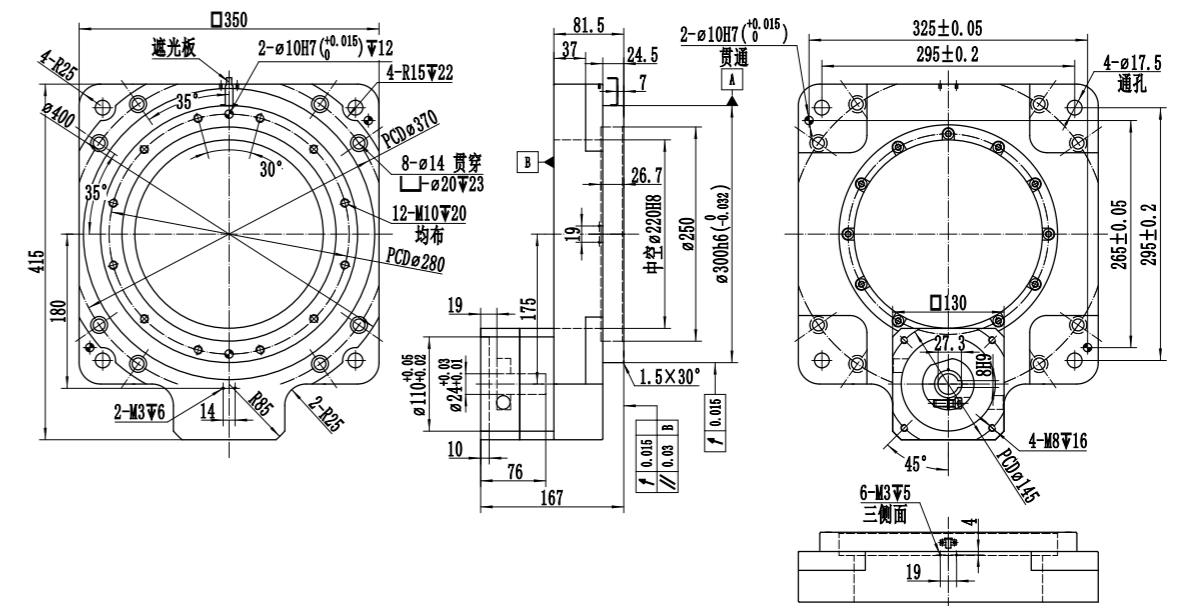

Ratio 10/18 dimension(motor shaft OD 35mm)

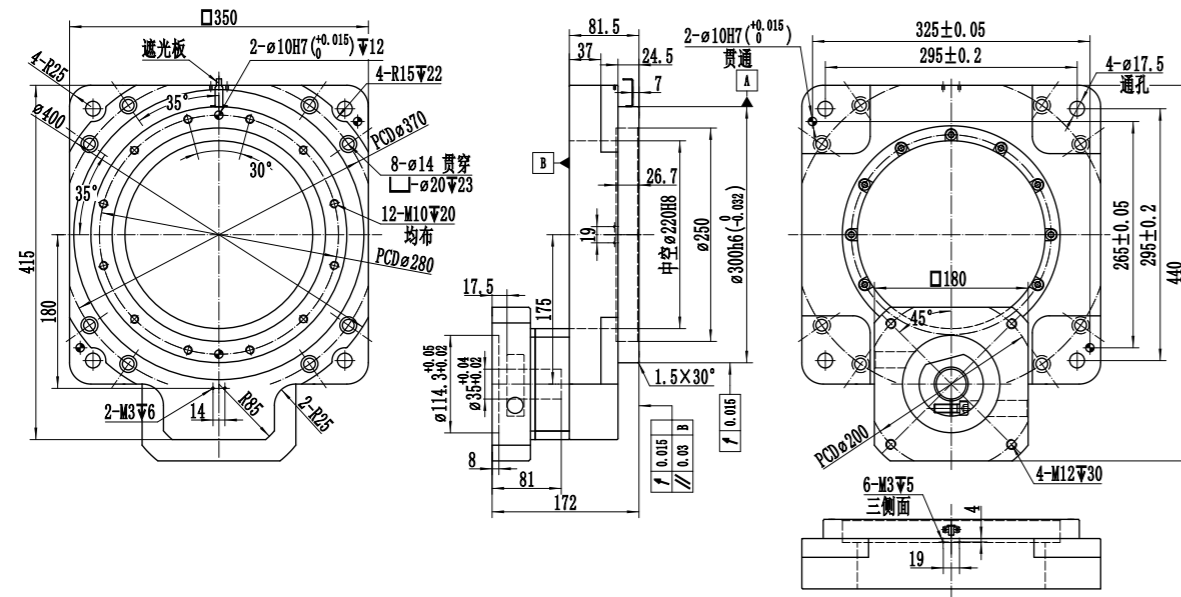

Combined gearbox dimension

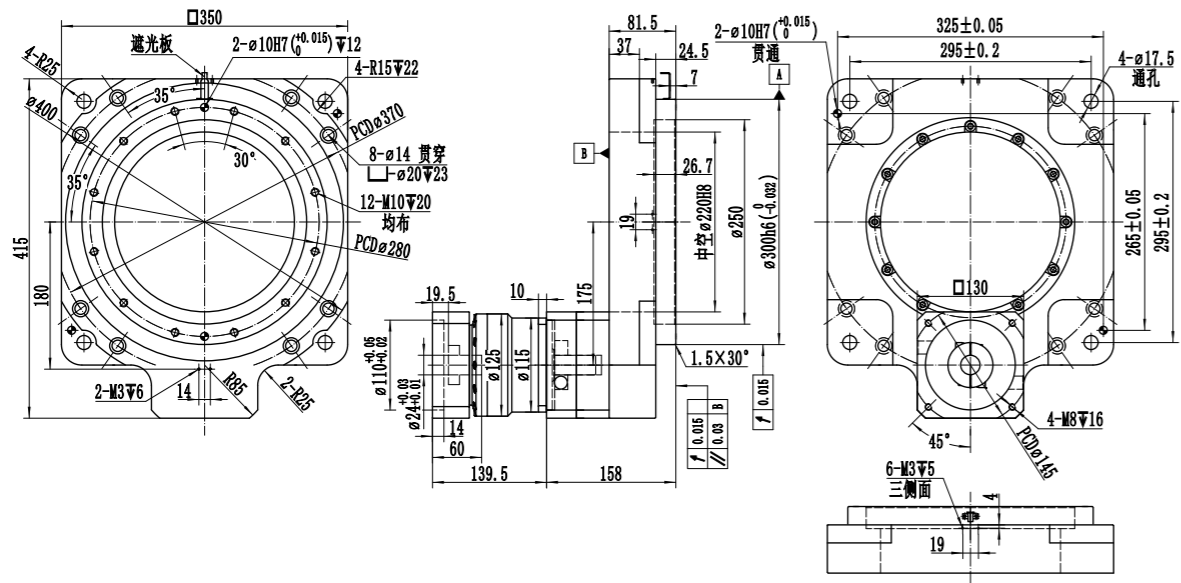

WTN450 Heavy-load type

Performance

Specifications	Unit	WTN450	WTN450+WVRB115
Applicable motor models		130 stepper motor	1000W-5500W servo motor motor shaft diameter≤38mm
Bearing type		crossed roller bearing	
Ratio		10	30 40 50 70 100
Rotational inertia	Kg.m <sup>2</sup>	80500X10-5	
Rated output torque	N·m	400	400
Emergency stop Torque T2NOT	rpm	Rated output torque	
Rated output speed	rpm	150	
Angular transmission accuracy	arcmin	<1	
Reset positioning accuracy	arcsec	<10	
Backlash	arcmin	<1	<1.5
Allowable axial load	N	11000	
Allowable moment of inertia	N·m	400	
Parallelism of rotation platform	mm	0.040	
Concentricity of rotation platform	mm	0.02	
Output end face runout	mm	0.02	
Noise	dB	75	66
Service life	h	20000	
Protection level	IP	40	
Weight	Kg	49	56.8

Dimension(motor shaft OD 24mm)

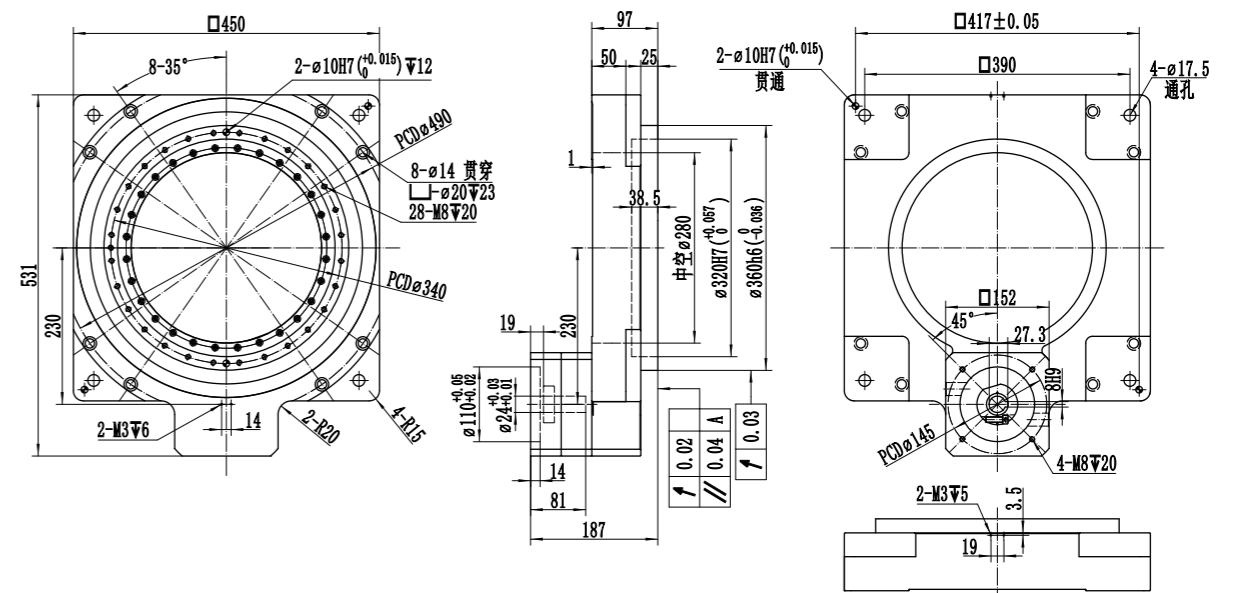

Dimension(motor shaft OD 35mm)

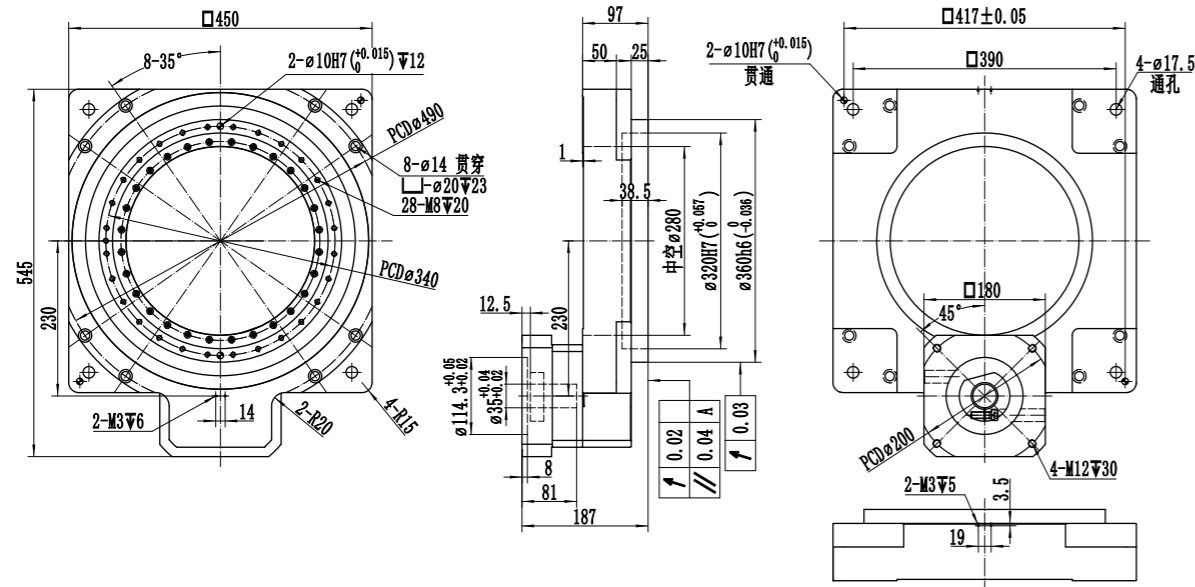

Combined gearbox dimension

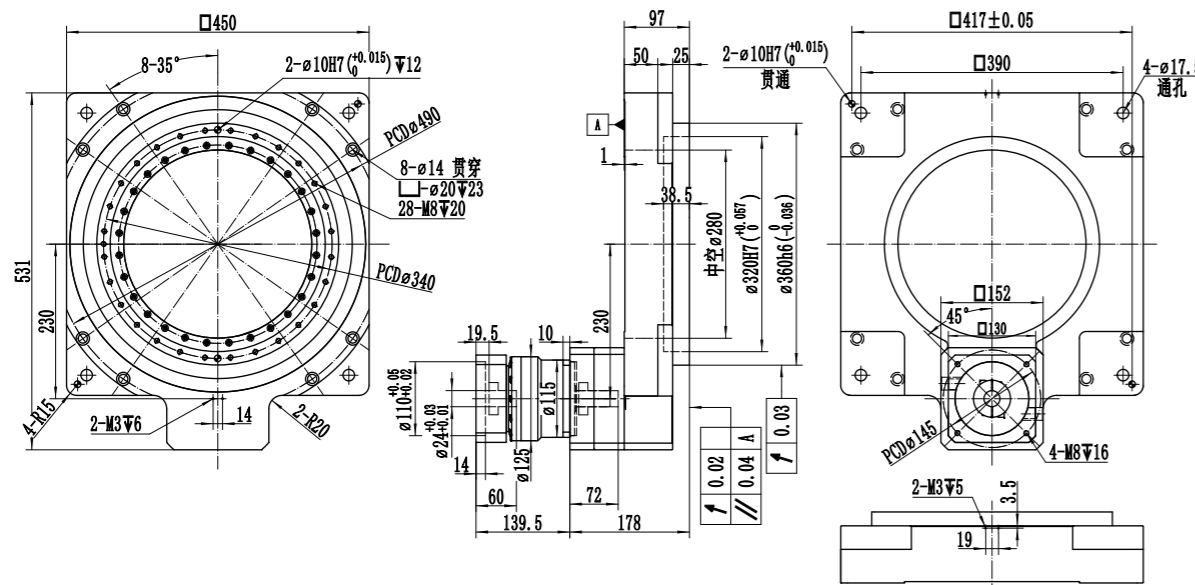

# SELECTION of Planetary Gearbox

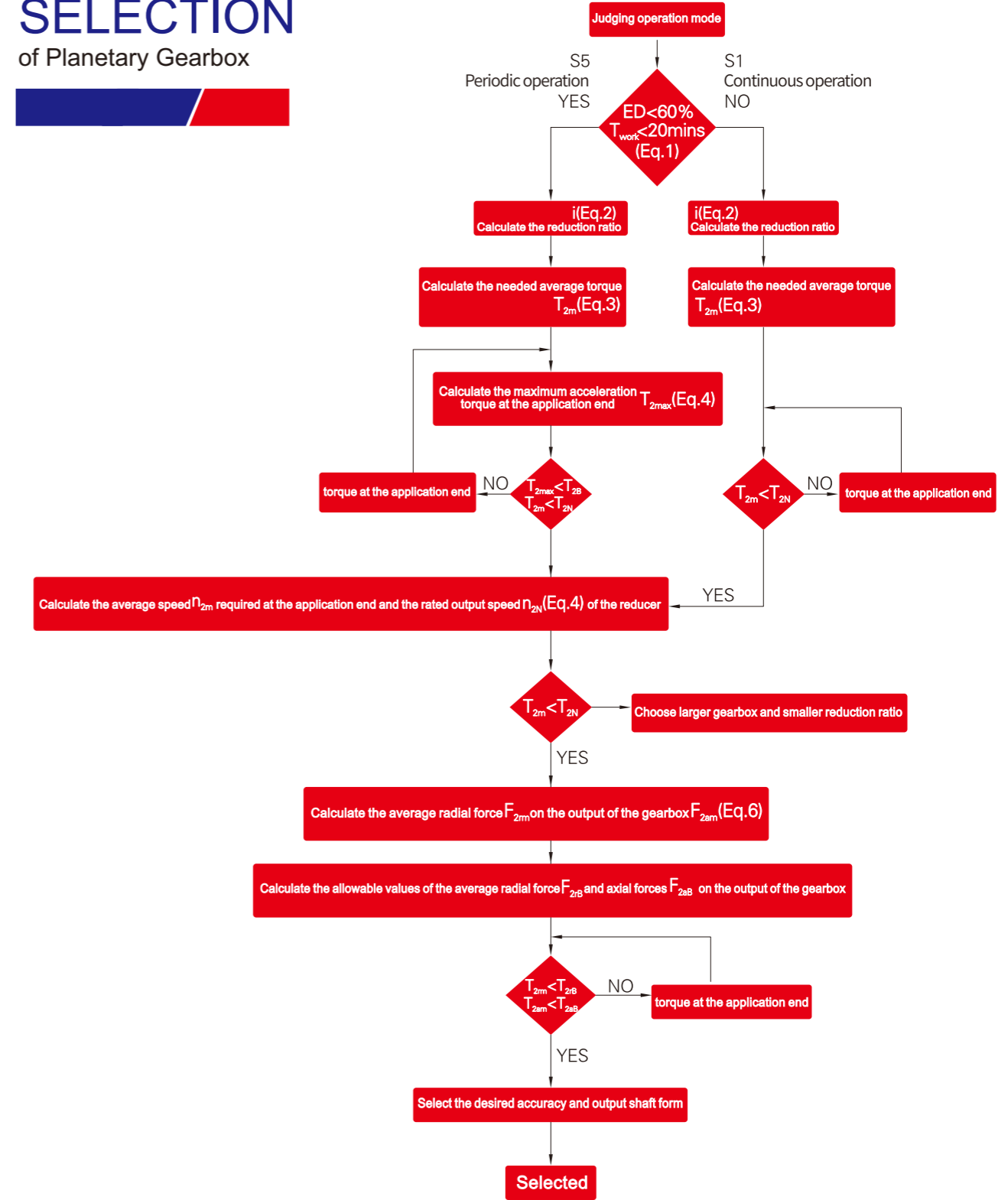

S5 suggestions for cycle operation  
General application inertia must conform to the following formula

$$\frac{J_L}{J_m} \leq 4 \times J_m$$

J<sub>L</sub>: Load inertia J<sub>m</sub>: Motor inertia

The most appropriate application inertia must conform to the following formula

$$\frac{J_L}{J_m} \approx J_m$$

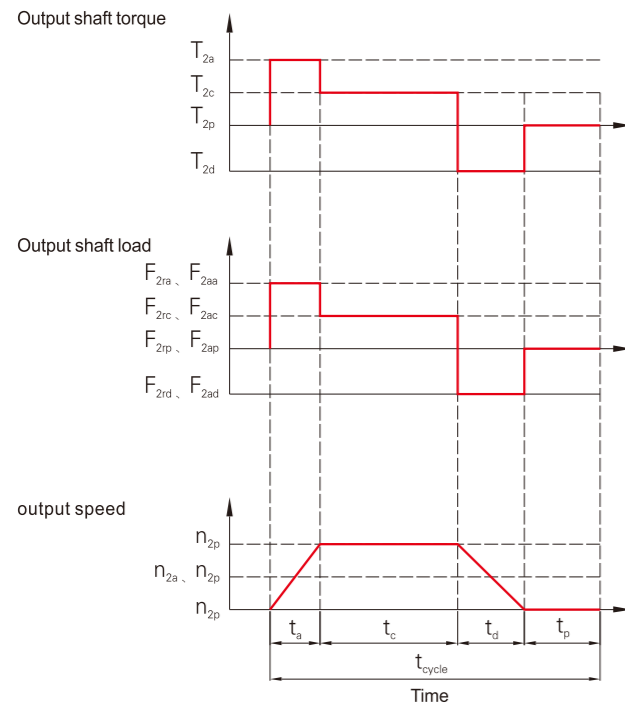

**1**  $ED = \frac{t_a + t_c + t_d}{t_{cycle}} \times 100\%$ ,  $t_{work} = t_a + t_c + t_d$  (Eq.1)

Subscript description:  
a.accelerate, c.constant, d.decelerate, p.stop

**2**  $i \approx \frac{n_m}{n_{work}}$  (Eq.2)

n<sub>m</sub>: Motor output speed n<sub>work</sub>: Actual application speed

**3**  $T_{2m} = 3 \sqrt{\frac{n_{2a} \times t_a \times T_{2a}^3 + n_{2c} \times t_c \times T_{2c}^3 + n_{2d} \times t_d \times T_{2d}^3}{n_{2a} \times t_a + n_{2c} \times t_c + n_{2d} \times t_d}}$  (Eq.3)

**4**  $T_{2max} = T_{mB} \times i \times k_x \times \eta$

Ks	Ks	周期次数 / 小时
负	1.0	0~1000
载	1.1	1000~1500
系	1.3	1500~2000
数	1.6	2000~3000
	1.8	3000~5000

T<sub>mB</sub> Motor maximum output torque  
η Gearbox operating efficiency (Eq.4)

**5**  $n_{2a} = n_{2d} = \frac{1}{2} \times n_{2c}$   
 $n_{2m} = \frac{n_{2a} \times t_a + n_{2c} \times t_c + n_{2d} \times t_d}{t_a + t_c + t_d}$   
 $n_{2N} = \frac{n_{IN}}{i}$  (Eq.5)

**6**  $F_{2m} = 3 \sqrt{\frac{n_{2a} \times t_a \times F_{2a}^3 + n_{2c} \times t_c \times F_{2c}^3 + n_{2d} \times t_d \times F_{2d}^3}{n_{2a} \times t_a + n_{2c} \times t_c + n_{2d} \times t_d}}$   
 $F_{2am} = 3 \sqrt{\frac{n_{2a} \times t_a \times F_{2aa}^3 + n_{2c} \times t_c \times F_{2cc}^3 + n_{2d} \times t_d \times F_{2dd}^3}{n_{2a} \times t_a + n_{2c} \times t_c + n_{2d} \times t_d}}$  (Eq.6)

## INSTALLATION OF PLANETARY REDUCERS

If your company install the planetary reducers by yourself, please comply with the following requirements:  
The size of the motor mounting flange of the planetary reducer differs according to the servo motor, the designated servo motor maybe not able to be installed. (Please be sure to install the designated servo motor when purchased)  
There may be rust inhibitor on the output shaft of the servo motor.

**1** Clean up the rust inhibitor and grease on the installing side of the motor shaft

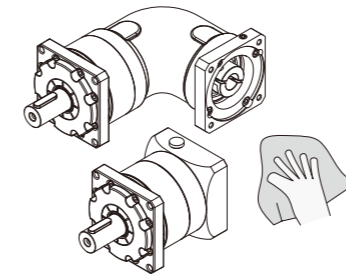

**2** Take off the plug

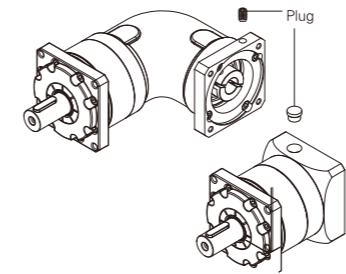

**3** Rotate the input shaft, and align the top of the fastening bolt at the plug hole. Make sure that the fastening bolt is loose at the time. Lay the reducer vertically on he flat place, and face up the installing side of the motor.(If there is a shaft sleeve, please install it as the picture shows below)

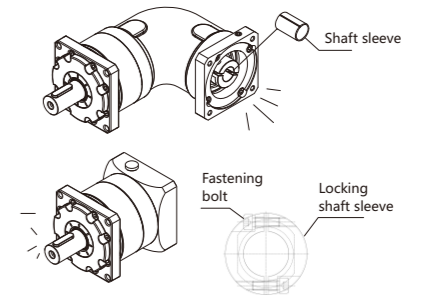

**4** Please insert the motor shaft into the input shaft slowly to avoid impact, and make sure the surfaces of the motor flange and the reducer flange are stick together. Fasten the motor mounting bolt according to the specified fastening torque. (Refer to the Table 3)

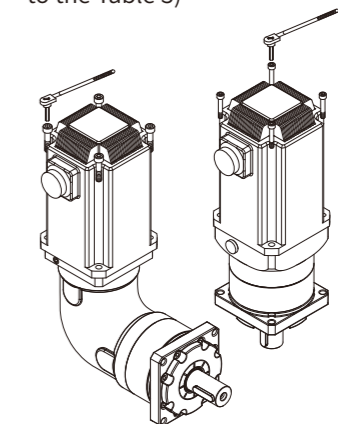
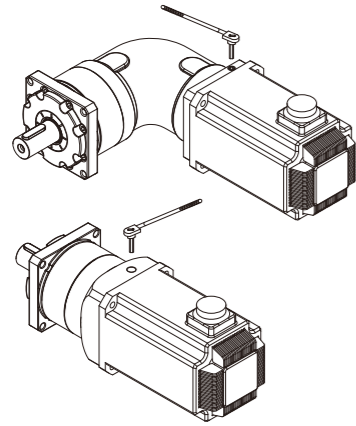

Diagram 3 Bolt fastening torque

Bolt size	M3	M4	M5	M6	M8	M10	M12	M16
Motor mounting bolt	N · m	1.0	2.5	5.1	8.7	21	42	134
	kgf · m	0.11	0.26	0.52	0.89	2.1	4.3	14
Fastening bolt	N · m	1.9	4.3	8.7	15	36	71	-
	kgf · m	0.18	0.44	0.89	1.5	3.7	7.2	-



- 5** Follow the specified fastening torque, and fasten the fastening bolt of the input shaft with the tools such as torque spanner.(Refer to the table 3)



- 6** Install the plug, and the installinn complete.

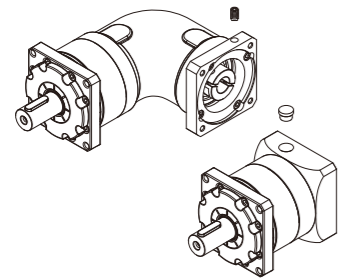

### Installation and setting up

- Please avoid using in places that are exposed to rain directly.(Please consult to WANSHSIN or our distributors first when using it outside or in places exposed to dust and water.)
  - Please fit it in the temperature under 0-40°C.
  - Please install it on the stable and firm surface, and fasten it tightly with bolt.
- During installation, it is necessary to ensure easy maintenance and inspection.

### Output shaft connecting

- When installing gear wheels, belt pulley and chain wheels on the output flange model, please use the installing design with bulged edges, and implant them into it. Avoid applying too much strength when installing.
- When installing coupling, chain wheels on the output shaft, please do not apply too much strength onto it. Do not knock too hard on the output shaft when implanting, or it may cause damages to the axletree and the interior part of the reducer.
- Too much gap between shaft and key in the coupling may cause firing so please be careful when installing.
- Please accurate centering when connect.

### Install it to the output flange(limited to the flange model)

- When installing the device component to the output flange, please follow the specified fastening torque and use the tools such as torque wrench.

Bolt size		M3	M4	M5	M6	M8	M10	M12	M16	M20
Fastening bolt	N · m	1.9	4.3	8.7	15	36	71	125	310	603
	kgf · m	0.18	0.44	0.89	1.5	3.7	7.2	13	32	62

\* Recommended strength level of the bolt is above 12.9

### Notes before starting

- The specified amount of lubricant has been added before delivery, so the reducers can be used directly when arrived.
- Please confirm the rolling direction of the output shaft and increase the load gradually at the first time operating.

### Notes need attention during operating

- Do not overloaded.  
The rolling speed of the output shaft should not be faster than the specified one.
- Please shut the machine down when following situation shows.
  - 1.The temperature rise suddenly.
  - 2.Strange noise are emerged.
  - 3.The rolling speed becomes unstable.
- The possible reasons are as follows, please make sure to deal with it in time.
  - 1.Whether it is overloaded or not?
  - 2.Are the axletrees, gear wheels and the rolling side damaged?
  - 3.Is the connecting condition abnormal?

### The lubricant managing

- The grease can not be replace.

### Daily check

- Whether the temperature of the reducer shell rise abnormally?(Maximum 90 °C)
- Are there any abnormal noise on axletrees or chain wheels.
- Is the reducer vibrating abnormally?(If it happens, please shut down the machine and contact WANSHSIN or our distributors)
- Is the lubricant leaking?(If it happens, please contact WANSHSIN or our distributors.)

### Regular check

- Whether it is overloaded or rolling abnormally?
- Is the belt pulley, chain wheel, the installation bolt of the reducer loose?
- The check and maintenance of main components. (When there is an abnormal phenomenon, please shut down the machine and contact WANSHSIN or our distributors.)